

RS-485 INTERFACE CONTROLLER

EM-481



OPERATING MANUAL

*Quality Management System of development and production complies with the requirements of
ISO 9001:2015*

Dear Customer,

NOVATEK-ELECTRO Ltd. Company thanks you for purchasing our products.
You will be able to use properly the device after carefully studying the Operation Manual.
Store the Operating Manual throughout the service life of the device.

- 3 -
CONTENTS

1 SERVICE	5
1.1 Device service	5
1.2 Controls, overall and mounting dimensions	6
1.3 Operation conditions	6
2 DELIVERY SET	7
3 TECHNICAL SPECIFICATIONS	7
4 DEVICE DESCRIPTION	8
5 THE INTENDED USE	8
5.1 Preparation for operation	8
5.1.1 Preparation for connection	7
5.1.2 General	7
5.1.3 Device connection	8
5.2 Using the device	9
5.2.1 General	9
5.2.2 Operation modes	10
5.2.2.1 Connection to the server	10
5.2.2.2 Monitoring of devices connected via RS-485	10
5.2.2.3 Access to MODBUS network using MODBUS TCP	10
5.2.2.4 Access to MODBUS network using SMS	10
5.2.2.5 Data collection and event tracking	11
5.3 Configuration	11
5.3.1 General	11
5.3.2 EM-481 parameters	11
5.3.3 EM-481 configuring via WEB-interface	23
5.3.4 EM-481 configuring via MODBUS-interface	23
6 MAINTENANCE	24
7 SERVICE LIFE AND MANUFACTURER WARRANTY	24
8 TRANSPORTATION AND STORAGE	24
9 ACCEPTANCE CERTIFICATE	24
10 CLAIMS DATA	25
Appendix A. Versions and modifications	26
Appendix B. Connections	27
Appendix C. Operation logic programming	31
Appendix D. Saving data to a memory card	43
Appendix E. WEB - interfaces	46
Appendix F. Updating of firmware	49

ATTENTION! ALL REQUIREMENTS OF THIS OPERATION MANUAL ARE COMPULSORY TO BE MET!



TO ENSURE THE DEVICE SAFE OPERATION IT IS STRICTLY FORBIDDEN THE FOLLOWING:

- TO CARRY OUT MOUNTING WORKS AND MAINTENANCE WITHOUT DISCONNECTING THE DEVICE FROM THE MAINS;**
- TO OPEN AND REPAIR THE DEVICE INDEPENDENTLY;**
- TO OPERATE THE DEVICE WITH MECHANICAL DAMAGES OF THE HOUSING.**

IT IS NOT ALLOWED WATER PENETRATION ON TERMINALS AND INTERNAL ELEMENTS OF THE DEVICE.

During operation and maintenance the regulatory document requirements must be met, namely:

- Regulations for Operation of Consumer Electrical Installations;
- Safety Rules for Operation of Consumer Electrical Installations;
- Occupational Safety in Operation of Electrical Installations.

Installation, adjustment and maintenance of the device must be performed by the skilled professionals having studied this Operating Manual.

The device is safe for use under keeping of the operating rules.

This Operating Manual is intended to familiarize you with the design, the requirements for safety, operation and maintenance procedures of the RS-485 interface controller EM-481 (hereinafter referred to as the "device", "EM-481").

The device meets the requirements of the following:

- EN 60947-1;
- EN 60947-6-2;
- EN 55011;
- EN 61000-4-2.

Harmful substances in amounts exceeding maximum permissible concentrations are not available.

The device versions are listed in Appendix A.

Terms and abbreviations:

- **10Base-T** is Ethernet standard for twisted pair communication with the speed of 10 Mbit/s;
- **100Base-T** is Ethernet standard for twisted pair communication with the speed of 100 Mbit/s;
- **8P8C/RJ45** is unified connector used for 10Base-T/100Base-T network connections;
- **ASCII** is standard character encoding table;
- **Client** is the device, which is addressing the other device (server) with the query to perform certain functions;
- **Display** is OLED graphical led;
- **DHCP** – It is the protocol that allows network nodes automatically obtaining the parameters of TCP/IP (IP address);
- **Ethernet** is a standard for packet network communication and transmitting data between units (e.g., PCs);
- **GPRS** is technology of data packet transmission by mobile communication;
- **GSM** The standard of digital mobile communication of the second generation;
- **HSPA** - The technology of high speed packet data transmission using mobile communication;
- **HTTP** is a protocol for transferring Web-pages and other data using "client-server" technology;
- **Indicator** is single LED indicator;
- **Internet** is the global routing system of units for storing and transferring data;
- **IP (protocol)** is routable protocol for transferring data by Ethernet. It is a part of TCP/IP and used for Internet;
- **IP (address)** is a node address, which is unique within a single network, operating via IP protocol;
- **IPv4** is four byte IP-address;
- **MAC (address)** – is the address used for device authentication during Ethernet transmissions. It is usually unique although qualified personnel can change it under certain circumstances;
- **MAC-48** is six byte MAC-address;
- **MODBUS** is the standard and protocol for packet communication using the "client-server" technology for industrial electronic units;
- **MODBUS RTU** is the communication protocol of the unit for byte wise transfer of the packet;
- **MODBUS ASCII** is communication protocol of the units for the transfer of packet in the form of ASCII-symbols;
- **MODBUS TCP** is the protocol for transferring Modbus packets using the TCP/IP standard;
- **NTP** - protocol for synchronizing clocks at network nodes with variable transmission delays;
- **Packet** is a block of data to be transmitted between devices;
- **RS-485/EIA-485** is network standard for communicating units using the twisted pair;
- **Server** is a unit, which performs specific functions upon query of other units;
- **SMS** is standard and technology of transmitting the brief messages via mobile communication;
- **TCP/IP** is the standard and a set of protocols for packet transferring data via the networks with delivery verification;
- **Twisted pair** is the pair of insulated conductors inside the cable, which are twisted together to reduce the distortion of the transmitted signals;
- **UMTS** - The third generation mobile communication system for GSM-based networks;
- **WEB** is the system for accessing documents on the servers, used in the Internet;
- **WEB-page** is the document, file and resource, which is available on the Web-server;
- **WEB-browser** is client for accessing the WEB-pages, which is primarily using the HTTP protocol.

1. SERVICE

1.1. Device service

EM-481 provides data collection from connected MODBUS devices, data transfer to the server, data access (via MODBUS TCP or SMS text messages), event tracking and response to events (sending SMS notifications, recording values to MODBUS devices, saving the read values to the log on the memory card).

EM-481 provides:

- Flexible options of connection (via wire or wireless communication GSM or UMTS, automatic method selection of communicating with a server, automatic or manual selection of GSM provider and communication parameters, resetting of MAC-address and other Ethernet settings;
- Protection of access (password for setting mode or connection to Modbus network, connection only to the

selected server with automatic login, password for control via SMS);

- Different modes of data interchange via MODBUS network (RTU or ASCII, with checking of parity for even-odds or without checking, wide range of transmitting rate, adjustable delay);
- programming the collection of data, events, and action for events (see Appendix C);
- Service functions (real time clock, firmware updating option).

1.2. Controls, overall and mounting dimensions

1.2.1. Overall and mounting dimensions of EM-481 are shown in Fig. 1.1.

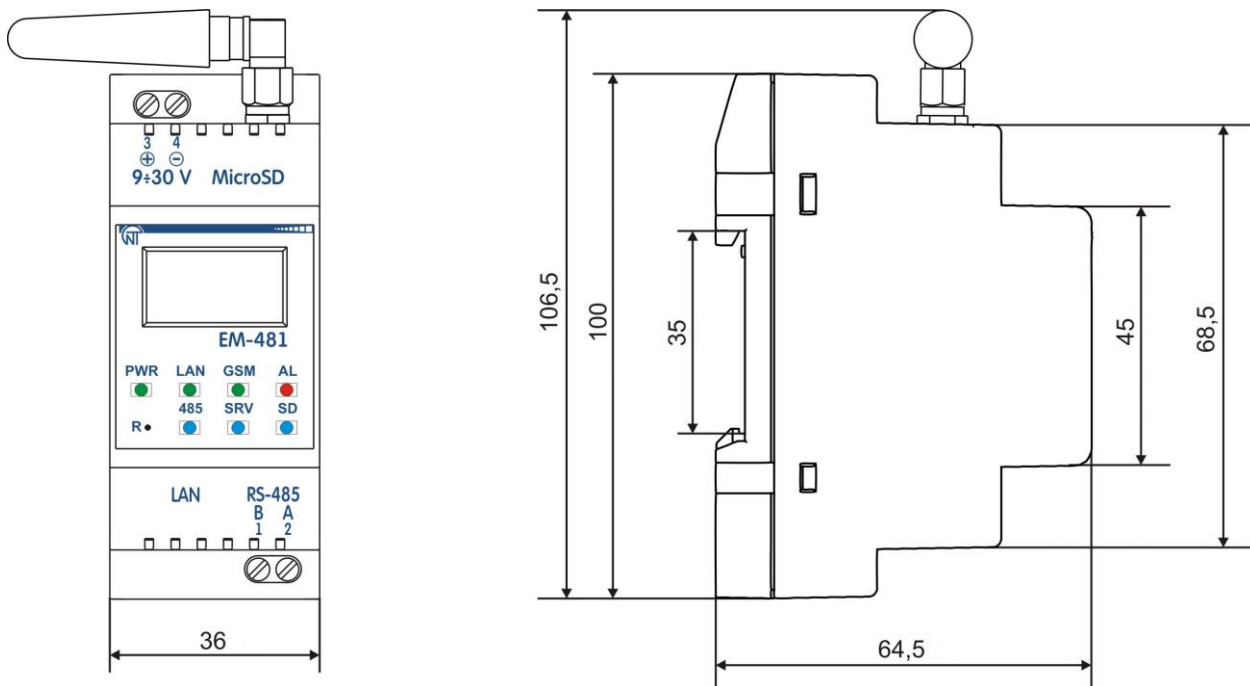
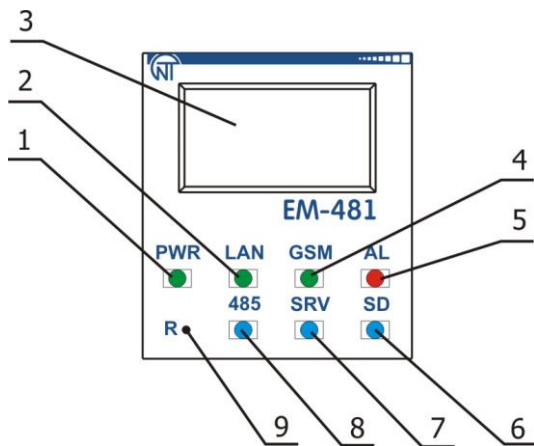

Figure 1.1 – Overall and mounting dimensions of EM-481

1.2.2. Controls are shown in Fig. 1.2.



- 1 – "PWR" LED is on when there is supply voltage;
- 2 – "LAN" LED is on when connected to Ethernet network, it blinks while the data exchanging via the network;
- 3 – The display serves to display the state of the device, the connections, the load of the communication interfaces, and showing of warnings about detected faults;
- 4 – "GSM" LED is blinking every 3 sec. when there is connection via GSM network or UMTS, it is blinking 3 times per second while data exchanging via GPRS or HSPA;
- 5 – "AL" LED warns about the registration of the fault in the course by analysis of the received data;
- 6 – "SD" is on when there is a memory card in a special slot, it is blinking while the data exchanging to SD-card;
- 7 – "SRV" is on when there is a connection with a server for data collation, it is blinking while data exchanging with the server;
- 8 – "485" is on when waiting a respond from the device in Modbus network; it is blinking while data exchanging via Modbus network;
- 9 – "R" reset button (is located under the housing, designed to restart the device or by thin non-conducting current subject).

Figure 1.2 – Controls of EM-481

1.3. Operation conditions

The device is intended for operation in the following conditions:

- Ambient temperature: from minus 35 to +55 °C;
- Atmospheric pressure: from 84 to 106.7 kPa;
- Relative humidity (at temperature of +25 °C): 30 ... 80 %.

ATTENTION! The device is not intended for operation in the following conditions:

- Significant vibration and shocks;
- High humidity;
- Aggressive environment with content in the air of acids, alkalis, etc., as well as severe contaminations (grease, oil, dust, etc.).

2. DELIVERY SET

The device delivery set is specified in Table 2.1.

Table 2.1 – Device delivery set

Description	QTY, pc
EM-481	1
Cable for Ethernet connection	1
GSM antenna (SMA M connector, 50 Ω)*	1
Memory card microSD (2 Gb)	1
Operation Manual; Technical Passport	1
Packing	1
Note: * other types of antennas are delivered in coordination with the buyer	

3. TECHNICAL SPECIFICATIONS

The device technical specifications are given in Table 3.1.

Table 3.1 – Technical Specifications

Description	Value
DC rated supply voltage, V	12
Data exchange interface via wired network	10Base-T/100Base-T
Supported Ethernet protocols	UDP, ARP, TCP
Data exchange interface via wireless network	GSM, UMTS
Supported standards of wireless network	SMS, GPRS, HSPA
Integrated servers	MODBUS TCP, HTTP
Maximum number of connections via Modbus TCP protocol	4
Data exchange interface via Modbus network	RS-485
Supported protocols of Modbus network MODBUS via RS-485	MODBUS RTU, MODBUS ASCII
Transmission speed in the MODBUS network via RS-485, bit/s	75 – 921600
Maximal output voltage of driver RS-485, V	3.3
Short circuit output voltage of driver RS-485 (maximum), mA	250
Resistance of in-built terminator, Ohm	1000
The recommended number of connected devices in Modbus network: – when the input current of receivers on RS-485 bus is no more than 0.125 mA; – when the input current of receivers on RS-485 bus is no more than 1 mA;	256 max. 32 max.
Readiness time when power is applied, no more than, s	15*
The supply voltage at which the operability is maintained	9 – 30
Power consumption (under load), W, not more than	6
Device service	Switchgear and controlgear
Rated operating condition	Continuous
Protection class rating	IP20
Electric shock protection class	III
Climatic design version	NF 3.1
Overvoltage category	II
Rated voltage of insulation, V	450
Rated impulse withstand voltage, kV	2.5
Conductor cross-section for connecting to terminals, mm ²	0.5 – 3
Tightening torque of the terminal screws, N * m	0.4
Weight, kg, maximum	0.400
Overall dimensions (Fig. 1.1), H*B*L, mm – with installed GSM antenna – without GSM antenna	64.5x106.5x36 64.5x100x36
Installation (mounting) of the device is on standard 35 mm DIN-rail	
The device remains operational capability in any position in space	
Housing material - self-extinguishing plastic	
Notes: * Connections in Ethernet networks/Internet can take more time.	

4. DEVICE DESCRIPTION

The device provides control for MODBUS devices in RS-485 network via Ethernet interfaces or GPRS, or via SMS. The device also allows reading data of devices by MODBUS. The processor supports connection to cloud-based data collection server via Ethernet network with a help of microchip of physical interface of Ethernet (or via GPRS/HSPA with a help of in-built modem, if connection via Ethernet is not available).

In addition, the device can be connected via MODBUS TCP Protocol to exchange data with MODBUS devices, or with EM-481. The controller receives and processes SMS with a password and command read/write for Modbus devices.

When inserting a memory card the device reads the internal memory for operational logic - program for data collection and tracking of events. The program runs in the background mode. The collected data can be saved to a memory card in tabular or binary files.

The device stores the network settings, safety parameters, the logic of action, the collected data log in the built-in memory.

5. THE INTENDED USE

5.1. Preparation for operation

5.1.1. Preparation for connection:

- Unpack the device (we recommend to keep the original packing for the entire warranty period of the device operation);
- Check the device for damage after transportation; in case of such damages detection, contact the supplier or the manufacturer;
- Carefully study the Operating Manual (**pay special attention to the connection diagram to power the device**);
- If you have any questions regarding the installation of the device, please contact the manufacturer by telephone number indicated at the end of this Operating Manual.

5.1.2. General

If the temperature of the device after transportation or storage differs from the ambient temperature at which it is supposed to be operated, then before connecting to the mains keep the device under the operating conditions within two hours (because of condensation may be on the device elements).

ATTENTION! ALL CONNECTIONS MUST BE PERFORMED WHEN THE DEVICE IS DE-ENERGIZED.

Error when performing the installation works may damage the device and connected devices.

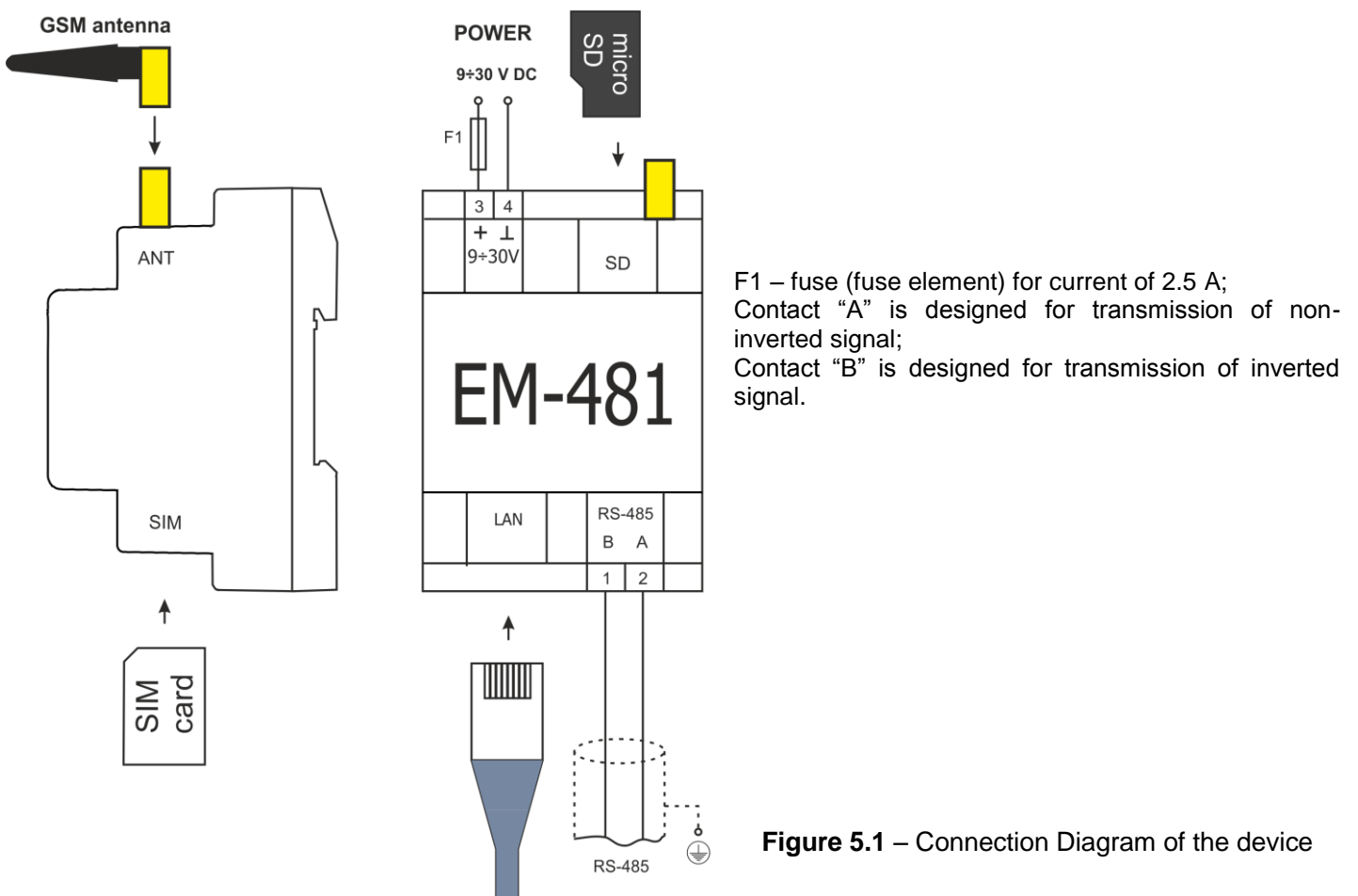

Figure 5.1 – Connection Diagram of the device

To ensure the reliability of electrical connections you should use flexible (stranded) wires, the ends of which it is necessary to be striped of insulation for 5 ± 0.5 mm and tightened with bootlaces. It is recommended to use the wire with cross-section of at least 1 mm².

- When connecting to the RS-485 bus, use twisted pair cable of category 1 or higher. It is recommended to use a shielded cable, in that case it should be grounded (in accordance with the recommendations "ANSI/TIA/EIA-485-A-1998").
- When connecting to Ethernet, use the cable supplied, or twisted pair cable of category 5e with 8P8C (RJ-45) lug. Wires fastening should exclude mechanical damage, twisting and abrasion of the wire insulation.

IT IS NOT ALLOWED TO LEAVE EXPOSED PORTIONS OF WIRE PROTRUDING BEYOND THE TERMINAL BLOCK.

For a reliable contact, tighten the terminal screws with the force indicated in Table 3.1.

When reducing the tightening torque, the junction point is heated, the terminal block may be melted and wire can burn. If you increase the tightening torque, it is possible to have thread failure of the terminal block screws or the compression of the connected wire.

To improve the performance of the device, it is recommended to install the fuse F1 (fuse element) or its equivalent in the EM-481 supply circuit for a current of no more than 2.5 A.

5.1.3. Device connection

5.1.3.1. Connect the device as per Fig. 5.1.

5.1.3.2. Connect the connection cable to the MODBUS network to the "RS-485" connector and to the MODBUS network (or directly to the device with the RS-485 interface).

5.1.3.3. If the EM-481 is to connect to the Internet through wired communication, to local network or directly to computer, connect the Ethernet connection cable to the Ethernet connector and to the Ethernet network. The details of connection depending on the type of wire line are indicated in Appendix B.

5.1.3.4. Connect power to the "9÷30V" power connector.

5.1.3.5. If the EM-481 is to connect to the Internet through wireless communication, put SIM card of the telecom operator in the SIM slot, and connect the GSM antenna to the ANT connector (SMA F connector).

5.2. Using the device

5.2.1. General

After power is turned on, all indicators except "LAN" and "GSM" light up, and EM-481 performs initialization. After that, for 2 seconds indicators, except for the power indicator, go out, and the device proceeds to start of communication interfaces with networks. In this case, the display shows general information about the device (Fig. 5.2). The start can take up to 15 seconds, depending on settings and the connection quality.

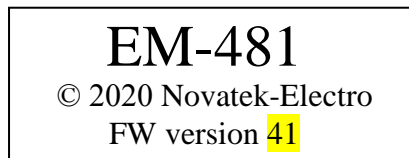

Figure 5.2 – Displaying of general information about the device on the display

After this, the EM-481 goes on to setting connection with the server and querying MODBUS devices.

ATTENTION! IF THE "AL" INDICATOR IS CONSTANTLY LITTING RED OR PERIODICALLY BLINKING RED AFTER EM-481 STARTING, PLEASE CONTACT THE PLACE OF THE MANUFACTURER OR PURCHASE OF THE DEVICE.

EM-481 provides and supports the connection to Ethernet and GSM/UMTS networks.

If the "LAN" indicator lights up, the connection to the network is successful. The blinking "LAN" LED indicates the data is being transmitted through the network.

If the "GSM" indicator blinks every three seconds, the connection to the GSM network or UMTS is set successfully. If the "GSM" indicator blinks three times per second, then the data is transmitted via GPRS or HSPA.

The display shows the load of the I/O interfaces, the GSM signal strength and the IP address used, as shown in Figure 5.3.



- “E: 5.2k” – the transmission speed via Ethernet is 5.2 kB/s;
- “2G: 7-0.3k” – the GSM signal level is 70 % and the GPRS transmission rate is 0.3 kB/s;
- “S: 15%” – the load of RS-485 is 15 %.
- “(E): 10.0.0.1” - connection to the local network with the address 10.0.0.1;
- “(G): 87.1.1.1” - wireless Internet access with the address 87.1.1.1.

Figure 5.3 – Displaying the status of connections on the display

5.2.2. Operation modes

5.2.2.1. Connection to the server

EM-481 provides and supports connection to the server specified in the settings. If “**SRV**” LED is on, it means that the connection to server has been done successfully. If “**SRV**” LED blinks, it means that there is data exchange with the server. The data exchange with server is made using one of two protocols: MODBUS TCP and modified MODBUS TCP.

5.2.2.2. Monitoring of devices connected via RS-485

The device inquires the MODBUS registers of devices connected via RS-485, upon queries from the server.

The MODBUS EM-481 registers can be specified in the server queries to read the current time, the EM-481 supply voltage, etc.

5.2.2.3. Access to MODBUS network using MODBUS TCP

EM-481 performs the function of Modbus gateway and waits for network connection via Modbus TCP protocol to port 502. The Modbus TCP connection port can be changed by the user. Connection to PC can be made by any programs - Modbus TCP clients. The client version for Windows software is available for download at the web-site of NOVATEK-ELECTRO Ltd (<http://novatek-electro.com/en/software.html>).

At inquiry for client connection to Modbus TCP port, EM-481 checks a list of available connections. If all connections are already engaged, the connection is cancelled otherwise the unit adds it into its internal list of service clients (no more than specified number of clients).

When connection with a client is set EM-481 waits for Modbus-inquiry from the client. In RS-485 slave mode, RS-485 requests from the MODBUS master are also accepted.

After receiving the query from the client, the device analyses the query and, depending on code of inquired function and actual rights of the client, processes or blocks it. In case of blocking the query EM-481 can generate and send to the client the specified by the user code of MODBUS exception (by default - code 1). The client's authority level is determined by the passwords entered after connection.

If the query is address to EM-481, the device does not re-direct it, but processes it and send the reply to the client.

In RS-485 master mode, queries to other devices are redirected to the MODBUS network, and a response is expected from the device in the MODBUS network, while the “**RS-485**” indicator lights up. If the data is received or the waiting time has expired, the “**RS-485**” indicator goes out.

In redirection mode to a remote server, if communication with remote MODBUS TCP server is set in Ethernet network or GSM/UMTS, queries to other devices are also sent to this server, and a response is expected from it.

Note: The respond is received from the first responding addressee; therefore, in the MODBUS network and among the addressees accessible via the remote MODBUS TCP server, there should not be devices with the same MODBUS addresses (identifiers).

If the query could not be redirected (for example, in the RS-485 slave mode, if the connection to the remote MODBUS TCP server was terminated), the EM-481 can generate and send the MODBUS user-defined exclusion code to the client (default code is 10).

If there is no reply, EM-481 can generate and send to the client the specified by the user code of Modbus exception (by default - code 11).

If there is a respond received on the query, EM-481 sends it to the client who had sent this query.

5.2.2.4. Access to MODBUS network using SMS

If there is GSM-connection set, EM-481 receives incoming SMS. All incoming SMS begin with a password. If the password does not match the one specified in settings, SMS is not processed and the reply SMS is not being sent back. After the password through the space the command is indicated.

The command consists of the following:

- from the access symbol (“**R**” for reading by MODBUS functions with codes from 1 to 4, “**W**” for writing by MODBUS functions with codes 5–6);
- the address (identifier) of the device in the MODBUS network;
- from the resource symbol (“**H**” for the most frequently used MODBUS registers for storing values, “**I**” for input registers, “**D**” for discrete inputs, “**C**” for flags);
- the address of the resource (register).

For the writing function, additionally after the space, the value to be placed at the address is indicated. For example:

- SMS message “abc r1h100” will send a query to read register 100 of device 1 (if the password for reading using SMS is specified as “abc” in the settings);
- The SMS message “stanc12 w2h174 5000” is used to write the value 5000 to the register 174 of device 2 (if the password for writing using SMS is specified as “stanc12” in the settings).

If the command format is correct, the device generates a MODBUS query, which is further processed in the same way as requests from other clients (see 5.2.2.3).

For the correct respond to the query, the EM-481 generates a response SMS. SMS starts with a command accepted earlier from the user. After the command, the value of the register used in the command (both for reading and writing) is indicated after a space. The presence of the value of the register in the SMS confirms the successful execution of the command. For example, SMS “r1h100 2200” means that the read command from device 1 has read the value 2200 of register 100.

If the response to the query is MODBUS exception code, the EM-481 generates SMS with exception message. **SMS begins with the command received earlier from the user.** After the command, the exclusion warning is indicated after a space. The warning consists of "EXC." line and the exception number. After the warning, text description of the exception with this number can be indicated after a space (standard exceptions to MODBUS are described in Table 5.2). For example, the message "r3h873 EXC.2 ILLEGAL DATA ADDRESS" means that for device 3 register with address 873 is not readable (or absent).

Table 5.2 – The standard Modbus exception codes

Code	Exception	Description
1	ILLEGAL FUNCTION	The received function code cannot be processed
2	ILLEGAL DATA ADDRESS	The data address specified in the query is not available
3	ILLEGAL DATA VALUE	The value contained in the query data field is invalid value
4	DEVICE FAILURE	Unrecoverable error has occurred when the addressee has tried to perform the requested action
5	ACKNOWLEDGE	The addressee accepted the request and processed it, but it takes a long time
6	DEVICE BUSY	The addressee is busy processing the command. The client can retry the message later
8	MEMORY PARITY ERROR	The parity error was detected when the addressee has tried to read the extended memory
10	GATEWAY PATHS NOT AVAILABLE	The gateway cannot redirect the query, since there is no path (connection) to the addressee
11	TARGET DEVICE FAILED TO RESPOND TO GATEWAY	The gateway did not receive a response to the forwarded query, because the addressee did not respond on time

5.2.2.5. Data collection and event tracking

When action logic program is loaded into the internal memory, the device reads the specified registers (connected devices or EM-481) at a specified interval, then performs the specified conversions and evaluates the received data. As a result, the following actions can be performed: writing the read values to the log on the memory card, SMS sending, writing to the specified register (connected device or EM-481). The program is loaded into the internal memory from the memory card. The procedure for preparing and downloading the program into the device is described in Appendix C.

5.3. Configuration

5.3.1. General

The connection settings of EM-481 is made via **HTTP** protocol or via **Modbus TCP** protocol and serves for specifying the main parameters needed for the device operation: types of connected sensors, exchange parameters via RS-485, parameters of address in Ethernet network (if Ethernet is used) and server address to which EM-481 is connected automatically.

The adjustable parameters are described in items 5.3.2. The parameters remain saved after the power cut off.

EM-481 setting can be made by two methods:

- Via WEB-interface (it. 5.3.3);
- Via Modbus-interface (it. 5.3.4).

ATTENTION! WHEN CHANGING EM-481PARAMETERS, THE VALUES MAY BE SET THAT INTERFERE OR BLOCK THE CONNECTIONS TO IT IN THE NETWORKS. IN THIS CASE, THE PARAMETERS SHOULD BE RESETTED TO THE FACTORY VALUES.

Safely remove of the memory card, restarting the device or reset of settings to factory values is executed by means of the “R” button available through a hole on a front panel. Non-conductive subject presses the button.

The reset of the device to factory settings:

- press and hold the reset button “R” for not less than 8 seconds (after 2 seconds of holding the indicator “AL” will light on); after 8 seconds of holding the device will restart, the indicators will blink one time;
- then release the button “R”.

To restart the device with saving of the user’s settings:

- press and hold the reset button “R” during time from 2 to 8 seconds;
- when “AL” indicator lights on, release the button “R”.

To display information about connections or safely remove of the memory card:

- press and release the reset button "R", the display shows information about connections, the indicator "SD" will go out. Remove the memory card, if necessary.

5.3.2. EM-481 parameters

The sets of parameters available via MODBUS protocol are provided in Table 5.3. The internal structure of all sets of parameters is similar to the structure of a set provided in Table 5.8, for exception of the initial address.

The format of parameters presentation in MODBUS registers is described in Table 5.4.

Parameters describing the device are given in Table 5.5.

The parameters of the device current mode are available for reading and writing and are provided in Table 5.6.

The parameters of current state are available only for reading and are described in Table 5.7.

The setting parameters are available only in the setting mode and are listed in Table 5.8.

Table 5.3 – The sets of parameters available via Modbus protocol

Set	Description	Access	Address
Changeable settings	The parameters listed in Table 5.8 that can be changed and activated as described in it. 5.3.3 and 5.3.4	Only in mode of setting, reading or writing	300 – 799, 5250 – 5499
Active settings	The settings being used by the device at the moment	In any mode, only reading	2300 – 2799, 5500 – 5749
Saved settings	The set is saved regardless the power of the device and is used at starting	Only in mode of setting, only reading	3300 – 3799, 5750 – 5999

Table 5.4 – Format of parameters presentation in Modbus registers

Parameter	Range of values	Description	Number of occupied registers
Number	0 – 65535	Whole number (16 bit) in standard range of Modbus register values	1
Number	-32768 – +32767	Whole number (16 bit) in complementary arithmetic	1
Number	0 – 4294967295 In two registers, Upper part – first	Whole number, which value can exceed the limit for Modbus register (65535)	2
Number	-2147483648 – +2147483647 in two registers, the upper part is the first	Whole number (32 bit) in complementary arithmetic	2
Character string	In every register – number of 0 to 255 - ASCII character code or 0 (the end of string)	A set of values, each of which is equal to the code of one character in the ASCII encoding. If the string is shorter than the maximum length, the last character is placed code 0	Max. length of string for this parameter
IP-address (IP-mask)	In every register – one byte (0–255)	Set of four byte of address IPv4, from left to right	4
MAC-address	In every register – one byte (0–255)	Set of six byte of address MAC-48, from left to right	6

Table 5.5 – Parameters describing the device

Parameter	Description	Address
Device type	The code that defines the MODBUS product by the manufacturer (23 – EM-481)	0
Firmware version	Firmware version of embedded software	1
Check code	CRC32 of firmware of embedded software	2 – 3

Table 5.6 – Parameters of the current mode

Parameter	Range of values	Initial volume	Description	Address
Entering password	String of characters	0	When entering a valid password, the client is given the appropriate permission (see registers 710 - 749) When you enter an empty string, the client rights are reset to the rights level at the time of connection	100–119
Control command	0–40959, Writing in the configuration mode	0	0: no activity; 1: "Restart" – EM-481 restart; 2: "Save" – save the changes of settings via MODBUS; 3: "Apply" - apply settings without restarting (only available for MODBUS and user parameters); 4: "Save and apply" - similarly to commands 2 and 3 sent one after another; 6: "Export" - read the saved settings and write them to a file on the memory card (see Appendix G); 7: "Import" - read settings from a file on a memory card and save them; 9: "Cancel" - to read the saved settings; 51: "Apply for Modbus" – apply settings via Modbus and RS-485; 59: "Apply for user" – apply settings for the user area of the registers; 81: "Synchronize clock with NTC server"; 82: "Obtain account balance from GSM operator"; 161: "Test SMS" - send a test SMS to the number of the main subscriber; 444: "Back to Factory Settings" - reset the settings to the factory settings;	

Table 5.6 Continued

Parameter	Range of values	Initial volume	Description	Address
			35381: "Start setting the clock" - it allows access to the registers of clock setting; 35431: "Cancel setting the clock" - it closes the access to the registers of the clock setting without changing hours; 40959: "Clear the internal memory of the tasks" - to erase the program for logic of actions (when the memory card is inserted, it will automatically read again)	120

Table 5.7 – Parameters of current state

Parameter	Description	Address
Mode (see details for reg. 122)	0: User's mode; 1: Setting mode.	121
Tabs of access	Bit 0 The ability for the connected client to obtain the permission (with the help of a password) for queries of the functions of reading devices by RS-485: 0 - permission cannot be obtained; 1 - permission can be received by the password	122
	Bit 1 Permission for the connected client for queries of the functions of reading devices via RS-485: 0 - no permission; 1 - there is permission	
	Bit 2 The ability for the connected client to obtain the permission (with the help of a password) for queries of the functions of recording and controlling devices by RS-485: 0 - permission cannot be obtained; 1 - permission can be received by the password.	
	Bit 3 Permission for the connected client for queries of the functions of recording and controlling devices via RS-485: 0 - no permission; 1 - there is permission	
	Bit 4 Ability for the connected client to obtain permission (with the help of a password) to access the EM-481 registers, except for the registers of version, password, mode and access tabs: 0 - permission cannot be obtained; 1 - the permission can be received by the password	
	Bit 5 Permission for the connected client to access the EM-481 registers, except for registers of version, password, mode and access tabs; 0 - no permission; 1 - there is permission	
	Bit 6 It is always as 1	
	Bit 7 Permission for the connected client to configure EM-481 (the same as register 121): 0 - no permission; 1 - there is permission	
	Bit 8 It is always as 0	
	Bit 9 1 - the client has the right to connect (it is always read as "1" after connection)	
Bit 12 Permission for the connected client to set the clock: 0 - no permission; 1 - there is permission		
Time, min	Number of minutes since the moment of start-up	123 – 124
Number of MODBUS TCP clients	Number of occupied connections of MODBUS TCP	125
Limit of MODBUS TCP clients	Number of prospective clients of MODBUS TCP	126
Load of RS-485, query/s	Total number of query/s via RS-485	127
Effective load of RS-485, query/s	Number of responds without errors via RS-485 per second.	128
Load of RS-485 per second, %	Load of RS-485 for the last second considering the set rate of RS-485 and time of inactivity	129
Load of RS-485 per minute, %	Load of RS-485 for the last minute	130
Load of RS-485 for 5 minutes, %	Load of RS-485 for the last 5 minutes	131

Table 5.7 Continued

Parameter	Description	Address
Load of MODBUS TCP, query/s	The number of queries received from clients via MODBUS TCP per second.	132
Effective load of MODBUS TCP, query/s	Number of responds without errors being sent to the client via MODBUS TCP per second	133
Load of GSM, kB/s	Load of wireless channel with GSM being switched on	134
Load of Ethernet, 100 kB/s	Load of wire channel with Ethernet being switched on	135
Max. number of clients of MODBUS TCP	Maximal number of simultaneously connected clients via Modbus TCP - from the moment of start up	136
Max. load of MODBUS TCP, query/s	Maximal number of queries received per second from the clients via Modbus TCP - from the moment of start up	137
Max. load of RS-485, %	Maximal load of RS-485 for 5 minutes - from the moment of start up	138
Max. load of GSM, kB/s	Maximal load of GPRS - from the moment of start up	139
Current IP-address of Ethernet	IP-address, by which EM-481 device is accessible in Ethernet network*	140 – 143
Current MAC-address of Ethernet	MAC-address, by which EM-481 is detected in Ethernet network	144 – 149
Unused parameter	The parameter is reserved for compatibility	150 – 164
Time to connect to the data collection server	0 - connection to the data collection server is set; 1 - connection to the data collection server is performed; 2 - 65534: the number of seconds before reconnecting; 65535: connection to the server is not used.	165
Number of programmed restarts	Number of restarts in accordance to the user setting - for total operational time	166
Number of critical errors	Number of noted errors (failures) causing the restart of the device - for total operational time	167
Total operation time, min	The number of minutes of operating time - for the total operational time	168 – 169
Current time	Number of seconds since 1st of January of specified year (see reg. 172)	170 – 171
Year of countdown	Year, since 1 st of January which is taken for time counting	172
Time zone, min	Time zone, for the time count, number of minutes with sign as to UTC+00	173
Temperature, °C	Temperature inside EM-481	174
Power voltage, mV	Bus voltage of 12 V	175
Time to connect to the first remote Modbus TCP server	0 - connection to the remote server is set; 1 - connecting to the remote server; 2 - 65534: the number of seconds before reconnecting; 65535: Connection to the Modbus TCP server is not used.	176
Interface for connecting to the first remote Modbus TCP server	0 - the connection is not set; 1 - Ethernet connection is set; 2 - GPRS connection is set.	177
DST increment, min	Effective day saving time increment	178
Unused parameter	The parameter is reserved for compatibility	179 – 209
IP-address of client 1**	IP-address of client, 0.0.0.0 – not connected	180 – 183
Port of client 1**	Port of client, 0 – not connected	184
IP-address of client 2**	IP-address of client, 0.0.0.0 – not connected	185 – 188
Port of client 2**	Port of client, 0 – not connected	189
IP-address of client 3**	IP-address of client, 0.0.0.0 – not connected	190 – 193
Port of client 3**	Port of client, 0 – not connected	194
IP-address of client 4**	IP-address of client, 0.0.0.0 – not connected	195 – 198
Port of client 4**	Port of client, 0 – not connected	199
Unused parameter	The parameter is reserved for compatibility and is equal to 0	200 – 209
Year (current time)	Current year	210
Month (current time)	Current month	211
Day of the month (current time)	Current day of the month	212
Hour (current time)	Current hour	213
Minute (current time)	Current minute	214
Second (current time)	Current second	215
Day of week (current time)	Current day of week (1 - Monday)	216
Month (winter time)	Current month, excluding summer time	217

Table 5.7 Continued

Parameter	Description	Address
Day of the month (winter time)	Current day of the month, excluding summer time	218
Hour (winter time)	Current hour, excluding summer time	219
Unused parameter	The parameter is reserved for compatibility	220 – 229
Time of day, s	Number of seconds from midnight of the current day	230 – 231
Time of sunrise, s	0 – 86399: Number of seconds from midnight to sunrise; 86400: Sunrise is not observed on this day	232 – 233
Sunset time, s	-1: Sunset is not observed on this day; 0 – 86399: Number of seconds from midnight to sunset;	234 – 235
Time of day, ms	Number of milliseconds from midnight of the current day	236 – 237
Memory card occupancy, 0.01%	10000 – memory card is missing or full.	238
Estimated time spent on 1% of the memory card, days	0 – less than one day. 1 – 9999 - days for 1% of the memory card capacity 10,000 - more than 10,000 days 65535 – unknown	239
Time before connecting to the second remote Modbus TCP server, s	0 – connection to remote server has been established; 1 – connecting to remote server; 2 – 65534: number of seconds before reconnecting; 65535: connection to Modbus TCP server is not in use.	240
Interface for connecting to a second remote Modbus TCP server	0 – connection not established; 1 – Ethernet connection is established; 2 – GPRS connection is established.	241
Current IP-address of GSM**	IP-address obtained from GPRS* provider	900 – 903
Unused parameter	The parameter is reserved for compatibility	904 – 914
GSM signal level, %**	Signal level and quality of radio communication with GSM provider	915
Unused parameter	The parameter is reserved for compatibility	916 – 931
SIM card account status**	The account status received on the last USSD request (sent automatically once a day). As an account, the first number in the operator's response is taken. -2147483648 – the account status is unknown	932 – 933
Time for receiving the SIM card account value**	The number of seconds from January 1 of the specified year (see reg. 172). 0 – account status was not accepted	934 – 935
Unused parameter	Parameter reserved for compatibility.	936 – 940
Memory card capacity, kB	0 – card missing or unformatted in FAT / FAT32	941 – 942
The amount of data that has not been written to the memory card since the start, bytes	0 - there were no data record losses 4294967295 - more than 4 GB losses	943 – 944
User parameters of status	User parameters of status after starting take a value of 0. They can be used for storage and transmission to the server of values to be measured and calculated in the values files.	5000 – 5219
User parameters of statistics	They store the value for the operating time of the built-in battery for the clock. They can be used in the task files for statistics gathering or saving state	5220 – 5249

Notes:

* – IP-address of device in GSM network can be allocated dynamically. For the access to the device via GSM using its IP-address, please contact the GSM operator;
** – content of registers is available only in the setting mode.

Table 5.8 – Setting parameters

Parameter	Range of values	Factory setting	Description	Address
Ethernet network				
Static IP-address	IP-address	192.168.0.111	If the dynamic addressing is switched off or not available, IP-address of the device in Ethernet network is equal to this value	300 – 303

Table 5.8 Continued

Parameter	Range of values	Factory setting	Description	Address
Subnetwork mask	IP-mask	255.255.255.0	It is used only with static IP-address	304 – 307
Gateway	IP-address	192.168.0.1	It is used only together with static IP-address for communication with other networks, or as an address of DNS/DHCP servers	308 – 311
Switch on the dynamic addressing with a help of DHCP	0 – 1	1	0 - for addressing in Ethernet, the specified values of the IP address, mask and gateway are used; 1 - If DHCP server is available in the network, then IP address, mask and gateway are received from the server	312
Switch on the filter of IP-address of DHCP-server	0 – 1	0	It is used for dynamic addressing. 0 - the addressing data from the first responding DHCP server is received; 1 – the device receives addressing data only from DHCP-server with IP-address of the gateway	313
Switch on the use of server gateway DNS	0 – 1	1	It is used if DHCP is not available (switched off): 0: DNS of gateway is not used; 1: The gateway DNS is used to determine the IP addresses of other servers, if they are specified by host names	314
IP-address of DNS server	IP-address	8.8.8.8	It is used if DHCP is not available (switched off); When the server of DNS gateway is used, it sets IP-address of additional DNS server	315 –318
IP-address of additional DNS server	IP-address	0.0.0.0	It is used if DHCP is not available (switched off); 0.0.0.0 – it is not used	319 – 322
Enable MAC address override	0 – 1	0	0 - unique value for each device is used as MAC address; 1 - is used of manually set MAC address	323
MAC-address Ethernet set manually	MAC-address	Unique value for each device	It is used when manual MAC-address is enabled to identify the device in Ethernet network	324 – 329
GSM network				
PIN-code of SIM-card	0 – 65535	65535	0 – 9999: this code is used for the SIM card if it demands the PIN code; Other values: the code isn't used, SIM card and GSM are unavailable if the card demand a code	330
Enable automatic APN detection and USSD request of the GSM operator	0 – 1	1	0 – GPRS connection is established according to the manually specified APN parameters, to obtain the account status, the manually specified USSD request is sent; 1 – APN and USSD requests for account status are automatically determined for the operator by the ICCID code of the SIM card	331
Activate GPRS in roaming	0 – 1	1	0: GPRS is blocked in roaming; 1: GPRS may be used in roaming	332
Activate SMS in roaming	0 – 1	0	0 – SMS can be only received in roaming; 1 – SMS can be received and sent in roaming	333
Connection port via MODBUS TCP via GSM	0 – 65535	0	It is used for external connection to the device via GSM with static IP, for communication using the MODBUS TCP protocol. 0 – it is disabled	334
Parameter is not used	0	0	It is not used; it should be equal to 0 for compatibility	335 – 339
USSD request to receive an account	Character string		It is provided by the GSM service provider. Up to 12 characters. There cannot be any spaces in the line	340 – 351
APN log-in of GPRS service	Character string		Provided by the GSM service provider; up to 40 characters	352 – 391
APN password of GPRS service	Character string		Provided by the GSM service provider; up to 24 characters	392 – 415
APN address of host	Character string		Provided by the GSM service provider; up to 34 characters; there cannot be spaces in a string	416 – 449

Table 5.8 Continued

Parameter	Range of values	Factory setting	Description	Address
MODBUS network				
Connection port via MODBUS TCP	1 – 65535	502	It is used for external connection to EM-481 for exchange via MODBUS TCP protocol	450
Disconnect inactive clients	0 – 1	1	0 - MODBUS TCP connection is supported regardless of the time between requests from the client; 1 - disconnect clients that have not received requests for longer than a specified time	451
Max. response waiting time, s	0 – 600 000	90	Used if disconnection of inactive clients is selected	452 – 453
Enable the queue for the last made MODBUS TCP connection	0 – 1	0	0: connection via Modbus TCP is supported regardless of connection holding time; 1: If all connections via Modbus TCP are used, a new client inquiring for connection can be connected instead of the last connected client, if the time of connection holding on is more than the specified time	454
Max. time of last connection holding via Modbus TCP, ms	0 – 600 000	60 000	It is used if the queue for the last connection via Modbus TCP is enabled	455 – 456
Native Modbus-identifier of EM-481	0 – 247	111	0 - all queries are sent via MODBUS TCP to the MODBUS network, the device registers are unavailable by MODBUS TCP; 1-247 - the device responds MODBUS TCP queries with this MODBUS identifier without sending them to the MODBUS network	457
Bit rate via RS-485, bit/sec	75 – 921 600	9600	It is used in case of data exchange between the devices via RS-485, the same value for the devices on the same bus-bar	458 – 459
Activate selection of byte format when transmitting via RS- 485	0 – 1	1	It is used in case of data exchange between the devices via RS-485, the same value for the devices on the same bus-bar. 0 – unused, byte is completed with 2 stop bits; 1 – Byte format is selected in register 461	460
Byte format when transmitting via RS-485	0 – 5	5	It is used in case of data exchange between the devices via RS-485 only if byte format selection is activated. The same value for the devices on the same bus-bar. 0 – “EVEN” – 1 parity bit and 1 stop bit; 1 – “ODD” – 1 parity bit and 1 stop bit; 2 – «0» (“SPACE”) – 1 zero bit and 1 stop bit; 3 – «1» (“MARK”) – 1 unit bit and 1 stop bit (similar to mode with two stop-bits); 4 – "ABSENT" - no parity bit, 1 stop bit; 5 – "AUTO-STOP" - no parity bit, 2 stop bits in the sent bytes, 1 stop bit in the received bytes (in such a case, devices with one and two stop bits may be connected simultaneously)	461
Waiting time for starting the MODBUS RTU response, ms	0 – 60000	200	It is used for transmissions via RS-485 in RTU mode. After transmission of query, if the first byte of the response was not received within this time interval, the waiting for the response is terminated. The response is always expected to be not less than the silence time between frames (the silence time de-pends on the transmission speed and is equal to the transmission time of 3.5 bytes, or 1.75 ms for speeds above 19200 bps)	462
Enable ASCII exchange mode in MODBUS network	0 – 1	0	Exchange mode via RS-485, the same value for all units on the same bus-bar. 0 – RTU exchange mode (format: 1 start bit, 8 data bits, 2 stop-bits, parity bit, and stop bit or only 1 stop bit - total from 10 to11 bits); 1 – ASCII exchange mode (format: 1 start bit, 7 data bits, 2 stop-bits or parity bit and stop bit - total is 10 bits). The non-standard byte formats (register 461, values 4 and 5) are not available in this case, format 3 (2 stop bits) is used instead	463

Table 5.8 Continued

Parameter	Range of values	Factory setting	Description	Address
Response time for subsequent Modbus ASCII character, ms	0 – 60 000	1000	It is used in case of data transfer via RS-485 in ASCII mode. If you receive a response, if the next byte of the response was not received within this time interval, then the response waiting is stopped. Waiting is always not less than the transmission time of one character (depends on the transmission speed)	464
Connecting to data collection server				
Mode of connection to the server for data collection	0 – 4	1	0 – connection to server is not used; 1 – It sets and supports connection to the server through the specified port of the server connection (port on the server side) through any of the available interfaces; 2 – passive mode, it is expected to connect from the server through the specified server connection port (port on the EM-481 side); 3 – similar to 1, but only via Ethernet; 4 – similar to 1, but only via GPRS	465
Server connection port	0 – 65535	20502	The port to which the party is addressed, making connection between EM-481 and the server (see reg. 465)	466
Time of waiting for response from the server, s	0 – 3600	120	0 – the server silence time is not limited; 1–3600 – max. time of server silence after which the connection will be stopped and must be remade again	467
Waiting time before reconnecting to the server, s	0 – 30 000	15	It is used when connecting to the server (except mode "2"). After losing connection to the server, the reconnection will be performed after the specified waiting time	468
Enable server address setting with a text string	0 – 1	1	It is used when connecting to the server (except mode "2"): 0 – connection is made to the server with fixed IP-address set in the registers 470 – 473; 1 – connection is made to the server with the name set in the registers 474–509	469
IP-address of the server	IP-address	0.0.0.0	It is used when connecting to the server (except for mode "2"), if the server address setting is turned off with text string. IP address of the remote server with which the connection is supported	470 – 473
Server address	Character string	modbus. overvis.com	It is used when connecting to the server (except for mode "2"), if the server address setting is turned on with text string. Address of the remote server with which the connection is supported. The string of up to 36 characters can be indicated as address. This string should not have any spaces	474 – 509
Protection				
Specified password for access to the mode of setting	Character string	11111	It is used to access the MODBUS TCP configuration mode. The string of 5 to 10 characters in length can be indicated as password. This string should not have any spaces	510 – 519
Parameter is not used	0	0	It is not used; it should be equal to 0 for compatibility	520 – 529
The specified password for recording permission using incoming SMS	Character string	gap	It is used to verify the authenticity of incoming SMS with request for record or with acknowledgment of the fault. The string of 3 to 10 characters in length can be indicated as password. This string should not have any spaces	530 – 539
The specified password for reading permission using incoming SMS	Character string	gap	It is used to verify the authenticity of incoming SMS with request for reading or with acknowledgment of the fault. The string of 3 to 10 characters in length can be indicated as password. This string should not have any spaces	540 – 549
The specified password for recording permission via MODBUS TCP in devices using RS-485	Character string		It is used to access devices connected to the EM-481, to request write or control functions that can change the status of these devices. The string to 10 characters in length can be indicated as password. This string should not have any spaces	550 – 559

Table 5.8 Continued

Parameter	Range of values	Factory setting	Description	Address
The specified password for reading permission via MODBUS TCP	Character string		It is used to access devices connected to the EM-481, to request read functions, or to access the EM-481 registers, except for registers of version, password, mode and tabs. The string to 10 characters in length can be indicated as password. This string should not have any spaces	560 – 569
Enable the protection mode against writing via SMS	0 – 1	0	0 – Protection against recording is regulated with help of other parameters (password); 1 – Blocking of queries via SMS for function of writing	570
Enable the protection mode against reading via SMS	0 – 1	0	0 – Protection against reading is regulated with help of other parameters (password); 1 – Blocking of queries via SMS for function of reading	571
Enable the protection mode against writing via MODBUS TCP	0 – 1	0	0 – Protection against recording is regulated with help of other parameters (password) or deactivated; 1 - Blocking of any queries for functions, excepting functions of MODBUS 1, 2, 3, 4, 7, 17, 20	572
Enable the protection mode against reading via MODBUS TCP	0 – 1	0	0 – Protection against reading is regulated with help of other parameters (password) or deactivated; 1 – Blocking of queries for functions of MODBUS 1, 2, 3, 4, 7, 17, 20, excepting reading using function 3 of registers of version, mode and tabs	573
Parameter is not used	0	0	It is not used; it should be equal to 0 for compatibility	574
Miscellaneous				
Parameter is not used	0	0	It is not used; it should be equal to 0 for compatibility	575 – 629
Enable automatic restart of the device	0 – 1	1	0 - the periodic restart is disabled; 1 - the device is restarted after a specified period of time	630
Restart time, min	5 – 7200	120	Used when automatic restart is enabled.	631
Enable restart mode automatically only when there are no connections	0 – 1	1	It is used when automatic restart is enabled: 0 - the device is restarted after a specified period of time since the start; 1 - the device is restarted after a specified period of time since the last transmission via Ethernet or GSM networks.	632
MODBUS exception code generated when access is denied	0 – 255	1	0 - if the access to MODBUS registers is denied, the response to the client is not returned; 1 - 255 - if you deny access to the client who sent the request, this exception code is returned	633
MODBUS exception code generated when there is no response	0 – 255	11	0 - if there is no response from the addressee (Gateway Timeout), the response to the client is not returned; 1 - 255 - if there is no response from the request recipient, this exception code is returned to the client	634
Parameter is not used	0	0	It is not used; it should be equal to 0 for compatibility	635
MODBUS exception code generated if there is no connection to query addressee	0 – 255	10	0 – If there is no connection to the query addressee (Gateway Path Unavailable), response is not returned to the client; 1 – 255 – if there is no connection to the query addressee, this exception code is returned to the client	636
Enable RS-485 slave mode	0 – 1	0	0 – Master mode: RS-485 is used to send queries; 1 – Slave mode: RS-485 is used to receive queries from additional client	637
First MODBUS-identifier of RS-485	1 – 255	1	Parameters define a range of MODBUS identifiers used for RS-485.	638
Last MODBUS-	1 – 255	255	In the master mode the queries with addresses in this range (and also the broadcast ones with address 0) are sent via	639

Table 5.8 Continued

Parameter	Range of values	Factory setting	Description	Address
identifier of RS-485			RS-485. In the slave mode the queries with addresses in this range (and also the broadcast ones and the queries to EM-481 address) are received via RS-485	
Connection to the first remote server of MODBUS TCP				
IP-address of remote server	IP-address	192.168.0.112	It is used when enabling redirection of queries to MODBUS TCP remote server. IP-address of the remote server wherewith connection is maintained	640 – 643
Port of the remote server connection	0 – 65535	502	It is used during redirection of queries to the remote server. The remote server port is for MODBUS TCP connection	644
Time to wait for response from remote server, ms	0 – 60 000	1000	It is used during redirection of queries to the remote server. After the query transfer, if the correct response failed to be received within this time interval, response waiting is stopped	645
Standby time to repeated connection to the remote server, ms	0 – 240	20	It is used during redirection of queries to the remote server. After connection with the server is lost, the repeated connection will be performed after preset standby time	646
Remote server connection mode	0 – 8	0	0 – MODBUS TCP remote server is not used; 1 – to connect to the server using Ethernet or GPRS, preferably via Ethernet; 2 – to connect to the server using Ethernet or GPRS, preferably via GPRS; 3 – to connect to the server only via Ethernet; 4 – to connect to the server only via GPRS; 5 – similar to 1 with virtual identifiers **; 6 – similar to 2 with virtual identifiers **; 7 – similar to 3 with virtual identifiers **; 8 – similar to 4 with virtual identifiers **	647
First MODBUS-identifier of the remote server	1 – 255	1	It is used during redirection of queries to the remote server. The parameters define the range of MODBUS identifiers used on the remote server.	648
Last MODBUS-identifier of the remote server	1 – 255	255	Queries with addresses in this range (and also the broadcast ones with address 0) are sent to the remote MODBUS TCP server	649
Parameter is not used	0	0	It is not used; it should be equal to 0 for compatibility	650 – 699
Automatic transition to daylight saving time				
Daylight saving time transition mode	0 – 200	12	0 – automatic transition is not used (the gain can be set manually when setting the clock) 1 – Brazil 6 – Italy 11 – Turkey 2 – Great Britain 7 – Namibia 12 – Ukraine 3 – Germany 8 – Poland 13 – Finland 4 – Greece 9 – Portugal 14 – France 5 – Jordan 10 – USA 15 – according to preset days;	700
Preset month for transition to daylight saving time	1 – 12	3	It is used if you selected the automatic transition to daylight saving time on the specified days. The month when the clock will be set one hour ahead	701
Preset week of the month for transition to daylight saving time	1–10	10	It is used if you selected the automatic transition to daylight saving time on the specified days. Week of the month when the clock will be set one hour ahead. 1–5 – week of the month, counting the part weeks; other values – the last week of the month	702
Preset day of the week for transition to daylight saving time	1–7	7	It is used if you selected the automatic transition to daylight saving time on the specified days. The day of the week when the clock will be set one hour ahead	703

Table 5.8 Continued

Parameter	Range of values	Factory setting	Description	Address
Preset hour for transition to daylight saving time	0 – 22	2	It is used if you selected the automatic transition to daylight saving time on the specified days. The hour of the day at which the clock will be set one hour ahead	704
Preset month of revert to standard time	1 – 12	10	It is used if you selected the automatic transition to daylight saving time on the specified days. The month when the clock will be set one hour back	705
Preset week of the month of revert to standard time	1 – 10	10	It is used if you selected the automatic transition to daylight saving time on the specified days. Week of the month when the clock will be set one hour back. 1–5 – week of the month, counting the part weeks; other values – the last week of the month	706
Preset day of the week of revert to standard time	1 – 7	7	It is used if you selected the automatic transition to daylight saving time on the specified days. The day of the week when the clock will be set one hour back	707
Preset hour of revert to standard time	1 – 23	3	It is used if you selected the automatic transition to daylight saving time on the specified days. The hour of the day at which the clock will be set one hour back	708
Calculation of sunrises and sunsets				
Sunny day	0 – 3	1	0 – official; 1 – civil; 2 – marine; 3 – astronomical;	709
Latitude, degree	0 – 89	46	The absolute value of the latitude	710
Latitude, minute	0 – 59	29		711
Latitude, second	0 – 59	10		712
Longitude, degree	0 – 179	30	The absolute value of the longitude	713
Longitude, minute	0 – 59	43		714
Longitude, second	0 – 59	40		715
Quadrant	0 – 3	0	0 – N latitude, E longitude; 1 – N latitude, W longitude; 2 – S latitude, E longitude; 3 – S latitude, W longitude	716
The connection to the server of NTP clock synchronization				
NTP server connection mode	0 – 4	0	0 – clock synchronization with the server is not used; 1 – to connect to the servers using Ethernet or GPRS, preferably via Ethernet; 2 – to connect to the servers using Ethernet or GPRS, preferably via GPRS; 3 – to connect to the servers only via Ethernet; 4 – to connect to the servers only via GPRS	717
Time period of connection to NTP servers, h	1 – 240	24	It is used if you have enabled synchronization of clocks with the server clock. The time interval over which the server time is received	718
Minimum shift of clock for synchronization, s	1 – 180	2	It is used if you have enabled synchronization of clocks with the server clock. The synchronization is performed after receiving the server time, if the difference between the clocks is no less than this value	719
Parameter is not used	0	0	Not used, must be equal 0 for compatibility	720 – 723
Logging				
Minimum supply voltage for safe removal of memory card, mV	0 – 24000	9000	If the supply voltage is below the specified value, the memory card will be removed safely. The card can be used again after the supply voltage exceeds the minimum plus 0.5 V. 0 - do not remove the memory card, including in a case if the supply voltage is unknown	724

Table 5.8 Continued

Parameter	Range of values	Factory setting	Description	Address
Format for logging parameters in task files	0 – 4	1	Used if there is a memory card and logging actions in task files. 0 - not used 1 - compact file of data bytes; 2 - CSV table with text separator ","; 3 - similar 2 with a separator ";"; 4 - similar to 2 with delimiter - tab character	725
Maximum limited size of log files, kV	0 – 65535	65535	Used if there is a memory card present, logging actions in task files, and logging is enabled. The size of the generated files is limited to the specified size plus 1 kV	726
Minimum stored period in recorder mode, days	0 – 255	30	Used if there is a memory card present, logging actions in task files, and logging is enabled. 0-183 - the oldest files (older than the specified number of days ago) can be deleted to write new data; Other values - old files are saved, new data recording is suspended when the memory card is full	727
Parameter is not used	0	0	Not used, must be equal to 0 for compatibility	728 – 739
Main subscriber phone number	Character string		Can be used to send SMS. Up to 20 characters. There can be no spaces in the line	740 – 759
Connecting to the second remote MODBUS TCP server				
Remote server IP address	IP address	192.168.0.13	Similar to 640–643	760 – 763
Remote server connection port	0 – 65535	502	Similar to 644	764
Waiting time for a response from a remote server, ms	0 – 60000	1000	Similar to 645	765
Waiting time before reconnecting to a remote server, ms	0 – 240	20	Similar to 646	766
Remote server connection mode	0 – 8	0	Similar to 647	767
First MODBUS identifier of the remote server	1 – 255	1	Similar to 648–649	768
Last MODBUS ID of the remote server	1 – 255	255		769
User settings				
User's settings and stored values	0 – 65535	0	They can be used to store any identification data of the device or for adjusting the settings of task files operation	5250 – 5499
Setting the clock*				
Adding day-light saving time, min	-1440 – +1440		Current gain. It is set during manual transition to the daylight saving time, when selecting the automatic mode it will be adjusted within 5 minutes. The value must be a multiple of 15	34817
Adding time zone, 15 min	-1440 – +1440	120	It is used during synchronization of the clock with the server clock. The value must be a multiple of 15	34818
Second	0 – 59		The time is to be set at the clock	34819
Minute	0 – 59			34820
Hour	0 – 23			34821
Day	1 – 31			34822
Month	1 – 12			34823
Year	0 – 65534			34824

Table 5.8 Continued

Parameter	Range of values	Factory setting	Description	Address
Set the clock	0 – 65535	0	It is used to set the clock. When recording to this register with any value, the new clock settings in registers 34817-34824 will be set	34825
<p>* – registers for the clock setting is available only in the clock setting mode, see registers 120, 122; ** - in the virtual identifier mode, before forwarding the request to the remote server, the virtual identifier of the addressee from the request is replaced by the real one so that the numbering in the server range starts from 1. For example, for the range 15-17, virtual identifier 16 will be replaced with real 2. Broadcast identifier 0 is processed without changes;</p>				

5.3.3. EM-481 configuring via WEB-interface

WEB-browser is used for setting via WEB-interface:

1) Write the IP-address of EM-481 in the address bar of the browser (to display the address on the display of the device, see it. 5.3.1) and select the transition to the specified address (the main page with the tab headings will be displayed for switching to other modes).

If the browser is set to use the proxy server, the access to the device via local network shall be granted only after adding the IP-address into the exceptions list as indicated in the browser documentation.

2) Select "Parameters" for setup of parameters. Password request shall appear before granting access to setup mode (factory setting 11111).

3) Enter password and press **ENTER**. If the password is correct, you shall be granted access to the setup mode. You will see the settings page. If the password is incorrect, the password request shall be displayed once again.

4) Settings on the settings page are grouped by types and are divided into tabs. Non-configurable settings and measurements are available in the tab "State". Settings on other tabs are listed in Table 5.8.

5) Click **SAVE** after making changes to the settings. This will check all the changed parameters. If no errors are detected, new parameters will be stored in the **EM-481** memory (new settings will take effect after the following application of settings or restart of the device). In case of any errors detected upon clicking the SAVE button, none of the parameters is saved, while the names of erroneous parameters are highlighted in red.

6) To apply the settings without restarting the device, you should click "**Apply**" at the bottom of the page. The entered settings will be checked. If the values of the parameters have not errors, the parameters will be stored in the memory of EM-481 and will come into force. Only parameters MODBUS and User's can be applied without restarting.

7) To set the clock on the tab "Time", press "**Set**" button.

8) Click "**Restore defaults**" to restore the default value of parameters.

9) Click "**Reset**" to stop all connections and interrupt all receive/transmit operations, with the following restart of the device. In case of any changes to the parameters, either introduced or stored in the memory, these changes shall be implemented.

If the addressing parameters in Ethernet network (MAC-address, IP- address) are modified and saved, the browser may not load the page after the restart of EM-481 by pressing the "Reset" button. This can happen as the browser continues to reply over the previous address. In this case, the connection should be made anew.

10) Clicking the "**Exit**" button the will close the setup mode and a password request appears once again.

5.3.4. EM-481 configuring via MODBUS-interface

Setting via Modbus-interface shall be provided if the device is connected using the Modbus client, which is supporting the Modbus TCP protocol. The connection is established using its IP-address (for display of the address on the device display see the it. 5.3.1) with the indication of Modbus-identifier (factory setting – 111).

Write the password string into the password input register (see Table 5.6) before setting parameters. Factory set password - is 11111, i.e. write 49 - ASCII-code for one to record the factory set password to registers 100 - 104. If the password is correct, the mode register (see Table 5.7) takes the value of "1" - setup mode.

The instruction registers (see Table 5.7), as well as registers for the collection of Modbus customizable parameters (see Table 5.8) are available for writing in the setup mode. When the required value is written to the registers of customizable parameters, write 2 (instruction for "**Saving**") in the instruction register. The accuracy of values for the stored parameters can be checked by comparing the collections of customizable parameters and saved parameters. If collections are the same, new values and settings shall be accepted and saved.

To apply the settings without restarting the device you should write into the parameter of the control command the value "4" - command "**Save and apply**". Only parameters MODBUS network and user's can be applied without the device restarting. The correctness of the saved parameter values can be checked by comparing the sets of configurable parameters and current settings. If the sets match, then the new settings are accepted and saved.

To cancel the changes in the parameters before saving them, you should write the value of "9" command in the control command parameter - the "**Cancel**" command. In this case, the configurable parameters take the values of the saved ones.

To reset the saved parameters to the factory settings in the configuration mode, you should write the value of "444" command in the control command parameter - **"Reset to factory"**.

In order for all saved parameter values to take effect, the device must be restarted. Through the MODBUS interface, the restart is performed by writing to the parameter of the control command the value "1" - the command **"Restart"**.

To exit the setup mode, write 0 instead of any character in password input register. This will clear all the password input registers and instruction register (turn the values to 0).

6. MAINTENANCE

6.1. Safety precautions



THE TERMINALS AND THE DEVICE INTERNAL ELEMENTS CONTAINS POTENTIALLY LETHAL VOLTAGE DURING MAINTENANCE IT IS NECESSARY TO DISABLE THE DEVICE AND CONNECTED DEVICES FROM THE MAINS.

6.2. Maintenance of the device must be performed by the skilled professionals.

6.3. Recommended frequency of maintenance is every **six months**.

6.4. Maintenance Procedure:

- 1) Check the connection reliability of the wires, if necessary, clamp with the force specified in Table 3.1;
- 2) Visually check the integrity of the housing, in case of detection of cracks and damages take the device out of service and send for repair;
- 3) If necessary, wipe the front panel and the housing of the device with cloth.

Do not use abrasives and solvents for cleaning.

7. SERVICE LIFE AND MANUFACTURER WARRANTY

7.1. The lifetime of the device is 10 years. Upon expiration of the service life, contact the manufacturer.

7.2. Shelf life is 3 years.

7.3. Warranty period of the device operation is 5 years from the date of sale.

During the warranty period of operation (in the case of failure of the device) the manufacturer is responsible for free repair of the device.

ATTENTION! IF THE DEVICE HAS BEEN OPERATED IN VIOLATION OF THE REQUIREMENTS OF THIS OPERATION MANUAL, THE USER WILL LOSE THE RIGHT TO WARRANTY MAINTENANCE.

7.4. Warranty service is performed at the place of purchase or by the manufacturer of the device.

7.5. Post-warranty service of the device is performed by the manufacturer at current rates.

7.6. Before sending for repair, the device should be packed in the original or other packing excluding mechanical damage.

You are kindly requested, in case of the device return and transfer it to the warranty (post-warranty) service please indicate detailed reason for the return in the field of the claims data.

8. TRANSPORTATION AND STORAGE

The device in the original package is permitted to be transported and stored at the temperature from minus 45 to +60 °C and relative humidity of no more than 80 %. When transporting the device, you should protect it against mechanical damage.

9. ACCEPTANCE CERTIFICATE

EM-481 has been manufactured and accepted in accordance with the requirements of current technical documentation and classified as fit for operation.

Head of QCD

Date of manufacture

Seal

10. CLAIMS DATA

The Company is grateful to you for the information about the quality of the device and suggestions for its operation.

For all questions, please contact the manufacturer:

NOVATEK-ELECTRO Ltd,
59, Admiral Lazarev Str.;
Odessa, 65007, Ukraine.
Tel.: +38 (048)738-00-28,
Tel./fax: +38 (0482) 34-36-73.
www.novatek-electro.com

Date of sale _____

VN201125

- 26 -
Appendix A
(mandatory)

Versions and modifications

Firmware versions are listed in Table A.1.

Table A.1 – Firmware versions

Version	Date of issue	Remarks
25	10.04.2017	<ul style="list-style-type: none"> • Demo version
26	27.04.2017	<ul style="list-style-type: none"> • Improved operation in slave mode using RS-485
27	6.06.2017	<ul style="list-style-type: none"> • Added support for statistical functions for variable ranges in task files
29	8.09.2017	<ul style="list-style-type: none"> • Support for task files in UTF-8 format is added. • Support for incoming GSM connections via Modbus TCP (for static IP provided by the GSM operator) is added. • The IP address in the GSM network is displayed alternately with the IP address in the local Ethernet network. • The operation speed with remote Modbus TCP server is improved. The speed of GSM operation is increased.
30	2.11.2017	<ul style="list-style-type: none"> • It is added the ability to execute task files more often than 1 second
32	6.12.2017	<ul style="list-style-type: none"> • It is added the ability to use in the task files the special sequences in the rows - telephone numbers
36	22.02.2018	<ul style="list-style-type: none"> • It is added the ability to receive account status from the GSM operator • It is increased stability of GSM operation • the clock synchronization and account receiving commands have been added
38	21.01.2020	<ul style="list-style-type: none"> • Parameters in the task file, located in a row for one device, are read by one request • Resetting current settings to factory defaults also clears the built-in memory of tasks before starting them • Improvements in work with statistics and hours registers • Improvements in the algorithm of the commands for calculating the maxima and minima in the problem files • The number of characters in lines in task files has been increased to 120 • • Extended support for WEB-browsers
41	20.11.2020	<ul style="list-style-type: none"> • Added the ability to log to a memory card • Added import and export of settings to a memory card • Simplified and improved work with the memory card from the WEB-interface • Added API JSON and XML for Modbus authorization and requests • Added a call to the WEB interface over Modbus connections • Added support for the second remote Modbus TCP server • Improved work with remote Modbus TCP servers • Improved DNS cache update • • Improved Ethernet stability

The device versions are specified in Table A.2.

Table A.2 – The device versions

Version	Date of issue	Remarks
1	10.04.2017	<ul style="list-style-type: none"> • First version

**Appendix B
(recommended)**

Connections

ATTENTION! CONNECTING THE INCORRECTLY SET DEVICE TO THE DATA TRANSMITTING NETWORK CAN INFLUENCE THE COMMUNICATION BETWEEN THE OTHER DEVICES. CONNECTION OF DEVICE EM-481 TO ETHERNET NETWORK NEEDS MUTUAL PARITY OF CONNECTED DEVICES SETTINGS. AS A RULE, ALL CONNECTIONS TO THE NETWORK LINKING MORE THAN 2 DEVICES, SHOULD BE MADE BY QUALIFIED PERSONAL (NETWORK ADMIN).

1. IP-addressing

When units are communicating over Ethernet network using TCP/IP protocol, every unit is using a set of IP-addressing settings to identify the sender and receiver of the data. The unit memory contains the personal and unique, within a single subnet, IP-address (four bytes are written as four integers, separated by dots, in the range of 0-255), subnet mask, which is the same for all units within the subnet (written similar to IP-address), and IP-address of the gateway, which is used to communicate with other networks. Proper communication between units of a subnet is possible under several conditions:

- 1) All units of a subnet have similar to mask. Most of small LANs are using 255.255.255.0 mask.
- 2) Mask starts with a group of bits set to "1", followed by a group of bits turned to "0".
- 3) All bits set to "1" in the mask are similar to for all the IP-addresses of units in subnet and indicate the subnet address. 192.168 is most frequently used address in LANs for the mask 255.255.255.0. The third byte may be used as a subnet number in a complex LAN. In smaller LANs, the third byte is usually equal to "0".
- 4) A set of bits in IP-address of the unit, which is set to "0" in the mask, is unique to each unit within the same subnet.
- 5) In most cases, the unit like router, which is already communicating with other networks, is switched to the network. This unit often gets the following address 192.168.0.1, 192.168.0.100, or 192.168.0.101. In this case, other units in the network shall have this IP-address of the unit as the gateway address. This address is not necessary for communication between units in a subnet, and is only used to connect units of one subnet to units of other networks.

Factory addressing settings for EM-481 are listed in Table B.1.

Table B.1 – Factory addressing settings for EM-481

Parameter	Value
Addressing using DHCP	Yes
IP-address	192.168.0.111
Subnet mask	255.255.255.0
Gateway	192.168.0.1

With the factory settings of the EM-481, two ways are possible for communicating with it via Ethernet:

a) The network uses a router or other DHCP server, which assigns IP addresses to new devices. In this case, it is sufficient to connect the EM-481 to the network, and after some time the obtained IP address is appeared on the display. The address "0.0.0.0" means that the desired value has not been received yet. The address is "192.168.0.111", obtained after 20-60 seconds after running EM-481, may mean that getting address from the DHCP server is failed and the device uses a static address;

b) The network is not able to use DHCP, or EM-481 is connected directly to the computer (or other device-client on the same subnet). In this case, EM-481 will switch to static addressing after some time (20-60 seconds) after starting. A client device should use a mask 255.255.255.0 as a mask and address starting with 192.168.0. The fourth byte of the address can take any value in the range from 1 to 254, except for 111. If the connection between EM-481 and a client unit is not provided directly but via a network with a number of units, the mentioned address cannot be equal to any of the addresses of other units on the subnet. If network has several units with the mask and the first three bytes of the IP-address, which are different from those specified in Table B.1, or the EM-481 factory IP-address is already taken, the configurable unit should be temporarily removed from the network to avoid addressing conflicts and establish a communication between this unit and EM-4816 directly. This will allow configuring the unit and EM-481 for direct communication or switching EM-481 to the network.

2. Configuring the client device to connect via Ethernet

The unit addressing is set according to documents and software it uses.

Below is an example of configuring the personal computer (PC) with Windows XP/7/8/10 to communicate directly with the EM-481 using factory settings.

Open the list of OS network connections to configure the network address in Windows. To do this, follow the steps below (mind the OS version).

For OS of Windows XP:

- 1) Log in as administrator;
- 2) Select Start-Control Panel;
- 3) If control panel items are divided into categories, select "Network and Internet Connections";
- 4) Go to "Network Connections".

For OS of Windows 7/8/10:

- 1) Log in as administrator;
- 2) Select Start-Control Panel;
- 3) If control panel items are divided into categories, select "Network and Internet";
- 4) Go to "Control Center Network and Sharing Center";
- 5) In the task bar (on the left), select "Change adapter settings".

Next, perform the following steps:

- 1) In the Connections window, select the desired connection via an adapter with the addressing that you want to change. Many computers have only one adapter and one connection, which will be displayed in this window. If the window shows several connections, select the connection you want, using the adapter name in the information on connection or contact your system administrator.
- 2) Click the icon of the connection with the right button, and select "Properties" in the drop-down menu. The Properties window opens (see Fig. B.1).

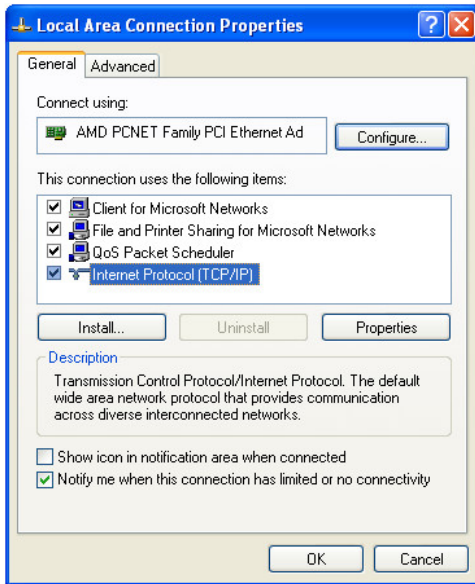

Fig. B.1 – Connection properties window in Windows OS

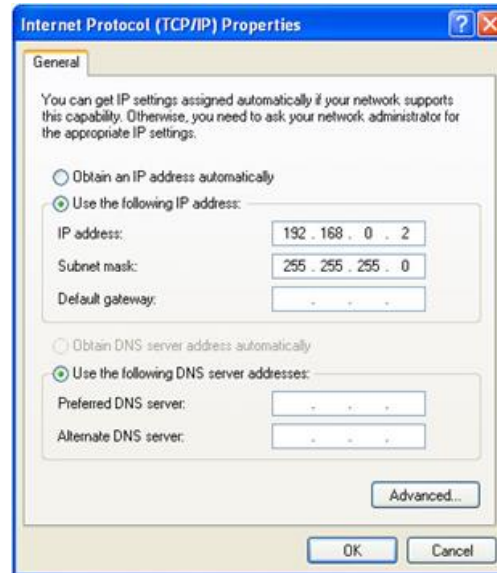

Fig. B.2 – TCP/IP properties window in Windows OS

- 3) Select "Internet Protocol (TCP/IP)" from the list of connection components in the next window. Make sure that the component is enabled (flagged in the list). Click "Properties". The TCP/IP properties window opens (see Fig. B.2).
- 4) Select "Use the following IP- address".
- 5) Specify the address in the "IP- address" field within the range from 192.168.0.1 to 192.168.0.255 (except for 192.168.0.111, which is used by EM-481).
- 6) Specify "255.255.255.0" in the "Subnet Mask" field.
- 7) The fields "Default Gateway", "Preferred DNS-server", and "Alternative DNS- server" should be left blank.
- 8) Press "OK" to close the Protocol Settings window.
- 9) Press "OK" to close the Connections Settings window.
- 10) If prompted by the OS to restart the PC after closing the windows, answer yes.

3. Connection to Internet via Ethernet

ATTENTION! THE USER IS STRONGLY RECOMMENDED TO CONNECT THE UNIT TO INTERNET UNDER THE SUPERVISION OF THE LAN SYSTEM ADMINISTRATOR AND/OR REPRESENTATIVE OF INTERNET SERVICE PROVIDER.

Use the following guidelines to connect the unit to Internet via Ethernet:

– Acquire a dedicated line with a static IP-address from your Internet Service Provider (hereinafter referred to as ISP). If static IP is unavailable, a part of functions (direct connection via MODBUS TCP or via the WEB interface) can be unavailable from Internet, at the same time connection to the server can be used in active mode;

– Direct connection of the unit to the ISP cable is not recommended; in case of a router connection, the ISP cable is connected to the "Uplink" socket on the router (It is usually marked with color and has no numbers. The marking depends on the router manufacturer, see the router documentation). The straight-through (supplied) Ethernet cable is used for connecting EM-481 unit to the router. Set the router for Internet connection as per ISP recommendations. The router settings should also provide for the redirection of queries, which are coming to static IP-address provided by the ISP, to the unit IP-address (factory setting - 192.168.0.111). If for a dedicated line the static IP address is fixed in Internet, and direct access from Internet to the product FTP, HTTP, MODBUS TCP servers is required, then in settings it is required to specify ports of redirection - for a local IP address of a device on which there is a redirection, it is necessary to specify 80 (for access to the WEB INTERFACE), 502 (for access on

MODBUS TCP). It will also necessary to disable DHCP in the settings of EM-481, or configuring the router for the provision of EM-481 via DHCP of always the same IP address;

- Verify if the Internet connection of EM-481 is protected by standard means (see below);
- When referring the EM-481 unit via Internet, use IP-address provided by your ISP.

4. GSM connection

ATTENTION! THE USER IS STRONGLY RECOMMENDED TO CONNECT THE UNIT TO INTERNET UNDER THE SUPERVISION OF REPRESENTATIVE OF MOBILE SERVICE PROVIDERS.

Make sure that your tariff plan includes providing GPRS service (for connection to Internet) and/or receiving and sending SMS messages (for control via SMS).

To connect the EM-481 device via GSM, use the following recommendations:

- From GSM provider (hereinafter referred to as a provider) you should get a SIM-card;
- Insert the SIM-card in the device and connect the appropriate antenna to have a proper radio signal in the place of the EM-481 device location;
- After starting the device, make sure that SIM-card has a correctly identification - after the communication initialization, the indicator GSM keeps on blinking; if the indicator is off for the time longer than 4 seconds, check the SIM-card, antenna and a level of GSM signal on the display of the device;
- If GPRS or HSPA are used for Internet connection, make sure, that the provider and settings are correct via code of SIM-card - when you enter the Internet, the GSM indicator flashes 3 times per second; if the indicator flashes less frequently, check the APN settings;
- In case of necessity, manually set the APN in accordance with the provider's recommendations.

5. Protection of connection:

- EM-481 has basic protection against unauthorized access via network;
- Access for writing and/or reading via Modbus TCP or via SMS can be deactivated in settings;
- The device settings can be changed remotely by entering the password (minimum 5 characters). Entering several incorrect passwords while trying to determine the correct one is blocked by the unit;
- Access passwords can be set for restriction of writing and/or reading via Modbus TCP or via SMS;
- When entering the password, all settings shall be only available to a given client using a given protocol. In case of no requests from the client over the long period, the access returns to locked mode;

ATTENTION! FOR ANY CONNECTIONS, EXCEPT GSM TRANSMISSIONS AND COMMUNICATION WITH THE DATA COLLECTION SERVER UNDER A SPECIALIZED DEVICE PROTOCOL, PASSWORDS ARE SENDED IN AN UNCRYPTED FORM. WITH THE CORRECTLY ENTERED PASSWORD, ACCESS OPENS IN AN UNSECURED CONNECTION.

- The unit protection system is not designed to counter malicious network attacks (especially those, which are not trying to get access to the unit but to block it instead);
- In case of complex and large networks (especially when providing access to the ET-481 via Internet), the users are recommended to separate the unit from unprotected networks with standard protective equipment (router, configured to filter the transmissions, Firewall, etc.).

6. Connection to the server

EM-481 has the mode of constant communication with the data collection and management server. For example Overvis system can be as a server (Internet-address: overvis.com).

Overvis – it is a system for monitoring and remote control of technological processes. Overvis makes it possible to read the data and make control over the devices including EM-481, provided there is a connection with them, to save the data in the base, review the data in appropriate form, to receive alarm messages as SMS or e-mail.

EM-481 factory settings are prepared for connection to Overvis.

Overvis system supports a special manner of identification which is used in EM-481. In addition the devices are verified by a unique MAC-address which is sent to the server at each connection session. The device registration for a user of the Overvis system is possible in two ways:

- a) if the device has a sticker with a QR code - read the code and follow the link, or enter the link from the sticker manually, and then follow the server instructions;
- b) to specify the activation code to a user account of Overvis. The code represents the number of 8 characters and is displayed on the display and on the status page of the WEB interface of the product after connecting to the server. When you enter code EM-481 is "attached" to a user account.

To connect a new device to the Overvis system using activation code you should:

- connect the EM-481 device to Internet via one of above mentioned methods;
- make sure (by information on the display or on the page of parameters of the unit WEB-interface state) that the connection to the server is made and the activation code is received;

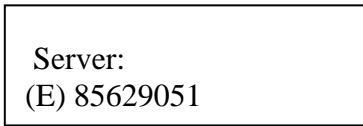

(E) – connection to the server via Ethernet

Fig. B.3 – Image of the activation code on the display

If for a device that is reconnected to Overvis, information is displayed that the connection is activated, or connection without a code, then for security reasons, you must click the "Restart activation" button at the bottom of the status page, in the settings via the WEB interface, to remove the device from Overvis. This ensures that the EM-481 will only be used by authorized users.

- Using the instruction on the site of Overvis system, connect to EM-481 with activation code; after activation during the connection to the server there will be shown on the unit display a message “activated”;
The message “no code” means that the device has been registered using the QR code on the sticker.



Fig. B.4 – Image of activation state on the display

FOR INFORMATION ABOUT EM-481 CONNECTION TO OTHER SERVERS, CONTACT THE DEVICE MANUFACTURER.

Appendix C (recommended)

Operation logic programming

1. General

After running, EM-481 starts execution of the program for logic of action, if it was placed earlier in the built-in memory. If there is no program in the built-in memory, EM-481 searches for and checks the task files placed in the folder "**TASKS**" on the memory card, provided the card is formatted in the FAT or FAT32 format. The correctly discovered files are read in the built-in memory and form the logic program of actions. Such a reading runs once after startup or after installing a new memory card, only if the built-in memory does not contain the programs.

To clean the internal memory you should:

- 1) Enter EM-481 parameter setting via WEB interface (see Manual, it. 5.3.3);
- 2) Go to the tab "Files";
- 3) Press the button "Clear internal memory of tasks";
- 4) If the result of the reading the program is not displayed immediately in the tab "Files", refresh the page a few seconds later.

Note: The program in the internal memory is deleted when updating the embedded software. If the memory card with the task files remains installed in the EM-481, the program will automatically read again after the update.

The tab "Files" indicates the result of reading the folder "**TASKS**", including the number of discovered and read files. If during reading and verifying the program errors were detected, then it indicates the type of error, file and line number of the file error. If the program consisted of several files in the folder "**TASKS**", then the internal memory will read all files except those in which errors are detected. Therefore, during error correction you should compare the number of discovered and read files and if some were read, to clear again the internal memory to re-read the program.

Files can have arbitrary names and extensions and placed in subfolders of the folder "**TASKS**". Files placed directly in the folder TASKS, allow you to use MODBUS ID default in the text, equal to MODBUS ID of the product EM-481. Files placed in subfolders in the folder "**TASKS**" with names from "1" to "247", allow to use the text MODBUS ID default name of the subfolder. Therefore, if the program logic is divided into tasks so that each is associated with its connected device, it is recommended that files relating only to EM-481, to be placed in the folder "**TASKS**" and files related to primarily the other device, to be put in a subfolder with the name of the MODBUS ID of this device. This allows you to change the list of managed devices by copying and renaming the subfolders, and create universal and portable files of the tasks.

2. Files of the tasks

File of tasks describes repeated after a specified time interval the set of actions for gathering, processing and comparing the data and special actions after fulfillment of the preset conditions according to the processing results.

The task file is divided into sections which in turn are divided into lines.

The section is part of the file that starts with "!" and the name of the section written in a row.

Correct example:

```
!META
* UPDATE 60
!PARAMS
...
```

Incorrect example:

```
META
* UPDATE 60
! PARAMS
...
```

If the section allows you to refer the lines in it, then all the lines of the section are numbered, otherwise instead of a number of the line will be put the sign "*". The format of the line is different in each section. The number and order of sections does not matter (sections can be interrupted and then be continued after one or more sections), if two rules are fulfilled:

- 1) If a section with numbered lines is found for the first time, the numbering starts with 0, otherwise, numbering continues from the previous section of the same name.

Correct example:

```
...
!VARS
0 VAL 0

!CONDS
0 VAREQVAL V0 0

!ACTS
0 ALARMON 1
1 ALARMOFF 1

!REACTS
* C0 ACT A0

!CONDS
1 NOT C0

!REACTS
* C1 ACT A1

...
```

Incorrect example:

```
...
!VARS
0 VAL 0

!CONDS
0 VAREQVAL V0 0

!ACTS
0 ALARMON 1
1 ALARMOFF 1

!REACTS
* C0 ACT A0

!CONDS
0 NOT C0

!REACTS
* C1 ACT A1

...
```

2) Link to another line should be below the line that is referenced.

Correct example:

```
...
!CONDS
0 VAREQVAL V0 0
1 NOT C0

...
```

Incorrect example:

```
...
!CONDS
0 NOT C1
1 VAREQVAL V0 0

...
```

The file should end with an empty line or a comment. The file should not have extra spaces, including at the end of lines. The file can contain comment lines that begin with “#”, and are ignored when reading the file.

Correct example:

```
...
# This is a comment
!VARS
# number of seconds per minute
0 VAL 60
1 VAL 1

...
```

Incorrect example:

```
...
# This is a comment
!VARS
0 VAL 60 # number of sec. in min
_1 VAL 1

...
```

Table C.1 – Sections assignment

META	General information and the file run settings
DEVICES	MODBUS devices capabilities
PARAMS	Parameters, registers and bits of MODBUS devices, and type conversion
VARs	Variables, transformation of parameters and calculations
PHONES	Phone numbers to which SMS are sent
STRs	Texts of messages to send to SMS
CONDS	Comparison of variables, the conditions for performing actions
ACTs	Actions that can be performed
REACTs	Reactions that determine under what conditions the actions will be fulfilled

2.1. META Section

It contains the general information about the file and settings for its execution, and is responsible for the particularities of the program cycle fulfillment (the so-called "updates"), including the frequency of updates. Lines in it do not have numbering, instead of index is "*". Each line has the following format:

* <modifier type> <argument>

The types of the arguments are the following:

- <int> - 32-bit signed integer
- <uchar> - 8-bit unsigned integer
- <ushort> - 16-bit unsigned integer

Table C.2 – Types of modifiers

PROTOCOLVERSION <int>	Version of the file: It prevents the processing of files with outdated firmware EM-481. The version described in this document is 9
UPDATE <int>	Frequency of the program cycle fulfillment (update rate) in seconds: Every cycle has the reading of parameters, calculation of variables values, defining operation conditions and implementation of response to these conditions. The frequency determines only the approximate time of the cycle restart. If during the task execution the time of the new update (this or another task) will be skipped, this new update will be postponed until the end of the running cycle. If one or more updates are missed for the deferred update, these additional updates will not be performed. The minimum value is 1 second. UPDATEDIVISOR modifier should be used for the higher speeds. By default, if a modifier is not specified, it equals to 60
UPDATEDIVISOR <int>	Updating rate divisor allows you to speed up the updating rate. If the divisor is 0, update cycles are performed with an accuracy of not more than 1 second. For other values, the accuracy is not more than 0.002 s, with the resulting frequency equal to the value of the UPDATE / UPDATE DIVISOR fraction, cannot be more than 60 s or less than 0.002 s. Practical limiting speed, as a rule, is less. The speed is significantly reduced when using SMS and parameters in the task file, which are accessed through RS-485 and GSM interfaces. By default, if no modifier is specified, it is 0
PARAMACTUAL <ushort>	Frequency of reading the parameters in seconds: It allows optimizing the number of readings of parameters. At the moment of the updating the parameter it is checked how many seconds ago it was read last time, and if this time is not more than the value PARAMACTUAL, then upgrade option will not be read and the last read value of the parameter will be accepted as current one. Thus, if the total program consists of several files, reading the same parameters, the number of readings of these parameters and the excessive load on the communication channels can be reduced. For the value 0 – with each update the parameter values will be read again. By default, if a modifier is not specified, it equals to 0
PARAMRETRIES <uchar>	Number of times to repeat reading in case of error: The value 0 for the programming cycle there will not be more than one attempt to read the parameter. For 1 – it will be made up to two attempts to read, etc. Calculations and reaction to conditions can be performed even without a successful reading of all parameters, if they have sufficient known data. By default, if a modifier is not specified, it equals to 0
PARAMTIMEOUT <int>	Time of waiting for response to MODBUS query in milliseconds: It is used if in the settings of EM-481 the total timeout MODBUS is more than frequency of update of this file, or if the exception code generation is disabled if no MODBUS response. By default, if a modifier is not specified, it equals to 1000
PARAMLOADRATIO <uchar>	Maximum load of RS-485 channel, in percent: After each query a delay is added, depending on the waiting time of the last response that allows other clients to send queries and receive responses. A value of 100 generates the minimum possible delays (it is not recommended). A value of 50 means a delay equal to the time of waiting for a response. A value of 25 means a delay of 3 times exceeding the response time. By default, if a modifier is not specified, it equals to 25

Example:

```
!META
* PROTOCOLVERSION 9
* UPDATE 5
* PARAMRETRIES 2
```

2.2. DEVICES Section

It contains the capabilities of MODBUS devices, the settings of not specified here devices will be treated the same as for the device with maximum features and functions. The lines in this section do not have numbering, instead of an index is "*". Each line has the following format:

* <MODBUS ID of device> <record type> <argument 1> [argument 2]

MODBUS device ID: a number from 1 to 247. "0" – is the broadcast, it can be used to configure recording simultaneously to all devices that support the broadcasting (the argument 1 in this case is defined, but not used). "*" instead of the MODBUS ID means a device by default for this folder (EM-481, if the file is placed directly in the program folder, or device with the MODBUS ID of the name of the subfolder, if the file is placed in the subfolder named "1" to "247").

Lines with different types or arguments, but with the same MODBUS ID are not permitted. These lines being in different files in the folder of programs are also considered to be incorrect.

Arguments type: <uchar> – 8-bit unsigned integer.

Table C.3 – Types of records

WRHANY <uchar> <uchar>	Device can write both as a function of 6 and function of 16 in the storage registers. The first argument specifies how many registers can be read in one query; the second one determines how many you can record in a single query
WRHMULTIPLE <uchar> <uchar>	Device can write only using function 16 in the storage registers. The first argument specifies how many registers can be read in one query; the second one determines how many you can record in a single query
WRHSINGLE <uchar>	Device can write only using function 6 in the single storage register. The argument specifies how many registers can be read in one query.
WRHDENIED <uchar>	Device can't write to the storage registers. The argument specifies how many registers can be read in one query

Example:

```
!DEVICES
* * WRHANY 50 50
* 3 WRHSINGLE 4
```

2.3. PARAMS Section

It contains parameters, their addressing, and conversion between types (how they are used by the device). When reading the settings are always converted from the specified type to the default type for the program EM-481 (INT32 – 32-bit signed integer). When recording the inverse transform is performed. The lines in this section are in ascending order, starting from zero. Each line has the following format:

<index> <MODBUS ID of device> <data type> <register table> <address>

Index: the sequential number of the line.

MODBUS ID of device: a number from 1 to 247. "0" – is the broadcast, it can be used for writing only. "*" instead of the MODBUS ID means a device by default for this folder (EM-481, if the file is placed directly in the program folder, or device with the MODBUS ID of the name of the subfolder, if the file is placed in the subfolder named "1" to "247").

Tables of registers:

- **H** - storage registers (most frequently used registers)
- **I** - input registers;
- **D** - digital inputs;
- **C** – tabs.

Address: a number from 0 to 65535.

Table C.4 – Data types

0	UINT16	16-bit unsigned integer. It occupies one register
1	INT16	16-bit signed integer
2	INT16BLE	16-bit signed integer with reverse order of byte transfer
3	INT32	32-bit signed integer. It occupies 2 registers
4	INT32BLE	32-bit signed integer with reverse order of bytes
5	INT32WLE	32-bit signed integer with reverse order of words
6	BIT	1-bit value for the digital inputs and flags
7	INT32BE	32-bit signed integer. For compatibility, the analog to INT32
8	F32EP0R	32-bit rounded to an integer with floating point
9	F32BLEEP0R	32-bit floating point, rounded to the nearest integer
10	F32WLEEP0R	32-bit reverse word order and floating point
11	F32EP1R	32-bit floating point multiplied by 10, rounded
12	F32BLEEP1R	32-bit big endian floating point * 10
13	F32WLEEP1R	32-bit reversed word order floating point * 10
14	F32EP2R	32-bit floating point multiplied by 100, rounded
15	F32BLEEP2R	32-bit big-endian floating point * 100
16	F32WLEEP2R	32-bit reversed word order floating point * 100
17	F32EP3R	32-bit floating point multiplied by 1000, rounded
18	F32BLEEP3R	32-bit big endian floating point * 1000
19	F32WLEEP3R	32-bit reversed word order floating point * 1000

Example:

```
!PARAMS
0 3 UINT16 H 240
```

2.4. VARS Section

It contains variables, processing the parameters and other calculations (e.g. the sum of the parameters). The lines in this section are in ascending order, starting from zero. Each line has the following format:

`<index> <source type> <argument 1> [argument 2]`

Index: the sequential number of the line.

The types of the arguments:

- `<bit number>` - is the bit number of the parameter from 0 and above. For 16-bit parameters it is no more than 15. For 32-bit parameters it is not more than 31;
- `<int>` - 32-bit signed integer;
- `<param ref>` - parameter reference of format Pn, where n is index of the parameter;
- `<var ref>` - variable reference of format Vn, where n is index of the variable.
- `<cond ref>` - reference to the Cn format condition, where n is the condition index

Table C.5 – Types of sources

COPY <var ref>	Copy the variable
VAL <int>	Set to the specified value
PARAMVAL <param ref>	Copy the value of the parameter
PARAMBIT <param ref> <bit number>	Copy one bit of the parameter value
PARAMERC <param ref>	Copy the last error code of MODBUS parameter
PARAMERN <param ref>	Copy the error counter of reading the parameter (it is reset to 0 after successful reading, and is incremented by 1 after each update, for which read attempts of the parameter was terminated)
VARADDVAR <var ref> <var ref>	Sum of two variables
VARADDVAL <var ref> <int>	The sum of the variable and a given value
VARMULVAR <var ref> <var ref>	Product of two variables
VARMULVAL <var ref> <int>	The product of a variable and a given value
VARSUBVAR <var ref> <var ref>	Difference of two variables
VARSUBVAL <var ref> <int>	The difference between a variable and a given value
VARDIVVAR <var ref> <var ref>	Quotient of two variables (the remainder is discarded)
VARDIVVAL <var ref> <int>	The quotient of variable and a given value (without remainder)
VARMODVAR <var ref> <var ref>	The remainder of the division of two variables
VARMODVAL <var ref> <int>	The remainder of the division of the variable by a given value
VARSMIN <var ref> <var ref>	The minimum of all variables in the specified range
VARSMINIDX <var ref> <var ref>	The number of the minimum variable in the specified range
VARSMAX <var ref> <var ref>	Maximum of all variables in the specified range
VARSMAXIDX <var ref> <var ref>	The number of the maximum variable in the specified range
VARSSUM <var ref> <var ref>	The sum of all variables in the specified range
VARSELBYC <var ref> <cond ref>	Choice of one variable from the range by condition - The value of that variable from the range (from the specified to the current one), the order of which in the range corresponds to the first condition that is fulfilled (starting from the specified one). To use such a variable, it is necessary to describe not only a list of variables above it, but also a list of conditions. Since the conditions usually refer to variables, such a list of conditions is placed "in a break" in the variable list, after which the variable is placed in the coninued "VARS" section. It is recommended that the last condition in the list be described in such a way that it is always fulfilled to limit the list

Example:

```
!VARS
0 PARAMBIT P0 0
```

2.5. STRS Section

It contains the text used as message for actions. The lines in this section are in ascending order, starting from zero. Each line has the following format:

<index> <text>

Index: the sequential number of the line.

Special sequences in the line text:

- *U* - MODBUS ID by default (reference to the number in the folder name where the file is located);
- *M0* - telephone number of the main subscriber (link to the line in the device settings);
- *<var ref>* - the value of the variable (reference to the variable, for example *V2*);
- ** - means one character *

Example:

```
!STRS
0 *U* - awaria 21: korotkoe zamykanie TS2
```

2.6. PHONES Section

It contains texts that are used for addressing SMS. The lines in this section are in ascending order, starting from zero. Each line has the following format:

<index> <text (phone number)>

Index: the sequential number of the line.

Special sequences in the text of the line:

- *U* - MODBUS ID by default (reference to the number in the folder name where the file is located);
- *M0* - telephone number of the main subscriber (link to the line in the device settings);
- *<var ref>* - the value of the variable (reference to the variable, for example *V2*);
- ** - means one character*

Note - if there are no numbers in the phone number other than 0, then SMS to this number will not be sent.

Example:

```
!PHONES
# Ivanoff - comment
0 067*V0*
```

2.7. CONDS Section

It contains conditions that compare variables. The lines in this section are in ascending order, starting from zero. Each line has the following format:

<index> <condition type> <argument 1> [argument 2]

Index: the sequential number of the line.

The types of the arguments:

- <int> - 32-bit signed integer;
- <cond ref> - reference to the condition of the format Cn, where n is the index of conditions;
- <var ref> - reference to the variable of format Vn, where n is the index of the variable;

Table C.6 – Condition types

IF <cond ref>	Copy of the condition
CONDIS <int>	Set to the specified value - The condition is met if the value is not 0. It can be used for adjustment or for unconditional actions for each update cycle
NOT <cond ref>	Logical NOT. The condition is satisfied, when the referred condition did not happen and vice versa
AND <cond ref> <cond ref>	Logical AND. Condition is satisfied, when both refereed conditions happened
OR <cond ref> <cond ref>	Logical OR. The condition is satisfied, when any referred conditions occurred
VAREQVAR <var ref> <var ref>	Comparison of two variables. The condition is fulfilled, if they are equal
VAREQVAL <var ref> <int>	Comparison of a variable with a specified value. The condition is fulfilled when a variable by reference is equal to the specified value
VARNEVAR <var ref> <var ref>	Comparison of two variables - The condition is met if they are not equal
VARNEVAL <var ref> <int>	Comparison of a variable with a given value - The condition is met when the reference variable is not equal to the specified value
VARGRVAR <var ref> <var ref>	Comparison of two variables. The condition is fulfilled when the first variable by reference is more than the second variable
VARGRVAL <var ref> <int>	Comparison of a variable with a specified value. The condition is fulfilled when a variable by reference is more than the specified value

VARLEVAR <var ref> <var ref>	Comparison of two variables - The condition is met when the first variable by reference is not greater than the second
VARLEVAL <var ref> <int>	Comparison of a variable with a given value - The condition is met when the reference variable is no larger than the specified value
VARLSVAR <var ref> <var ref>	Comparison of two variables - The condition is met when the first variable by reference is less than the second
VARLSVAL <var ref> <int>	Comparison of a variable with a given value - The condition is met when the reference variable is less than the specified value.
VARGEVAR <var ref> <var ref>	Comparison of two variables. The condition is fulfilled when the first variable by reference is not less than second variable
VARGEVAL <var ref> <int>	Comparison of a variable with a specified value. The condition is fulfilled when a variable by reference is not less than the specified value

Example:

```
!CONDS
0 VAREQVAL V0 1
1 NOT C0
```

2.8. ACTS Section

It contains actions that can be performed (action is performed only by references from the section of the reactions **REACTS**, during the performance of the conditions indicated there). The lines in this section are in ascending order, starting from zero. Each line has the following format:

<index> <action type> <argument 1> [argument 2]

Index: the sequential number of the line.

The types of the arguments:

- <int> - 32-bit signed integer;
- <alarm reason> - is the number of reason of the alarm – when any of the alarms is enabled, red LED of alarm is on, so to turn off the indicator, each of them needs to be turned off;
- <param ref> - reference to the parameter of format Pn, where n is the index of the parameter;
- <phone ref> - reference to the phone of format Hn, where n is the index of the phone;
- <str ref> - reference to the line of format Sn, where n is the index of the line;
- <var ref> - reference to variable of format Vn, where n is the index of the variable.

Table C.7 – Types of actions

ALARMON <alarm reason>	Turn on alarm LED. Red LED alarm will be on to the action of ALARMOFF with the same number of <alarm reason>.
ALARMOFF <alarm reason>	Turn off alarm LED
PARAMWRVAR <param ref> <var ref>	Record the parameter with the value of the variable
PARAMWRVAL <param ref> <int>	Record the parameter with the set value
SENDSMS <phone ref> <str ref>	Send SMS
PARAMLOG <param ref>	Write the parameter value to the log (see Appendix G).
PARAMCOMMENT <param ref> <str ref>	Write parameter value to log with comment. Comments are written only in tabular log format.
PARAMLOGCHGVAR <param ref> <var ref>	Write the parameter value to the log if it has changed by more than the specified variable.
PARAMLOGCHGVAL <param ref> <int>	Write the parameter value to the log if it has changed by more than the specified value.

Example:

```
!ACTS
0 SENDSMS H1 S0
1 PARAMWRVAL P0 31
```

2.9. REACTS Section

It contains the responses, a list of actions that must be performed under specified conditions. Lines do not have numbering, instead of an index is “*”. Each line has the following format:

* <cond ref> <response type> <act ref>

The types of the arguments:

- <cond ref> - reference to the condition of the format Cn, where n is the index of the condition;
- <act ref> - reference to the action of format An, where n is the index of the action.

Table C.8 – Types of responses

<cond ref> ACT <act ref>	Perform once. If the condition occurred, but did not occur in the previous update, the action will be performed once
<cond ref> REPEAT <act ref>	Perform each time. Regardless of the previous state, the action will be executed. The action will be executed even, if the state conditions are not defined in this update due to reading errors, but this condition has already happened earlier

Example:

```
!REACTS
* C0 ACT A0
* C1 REPEAT A1
```

3. Examples of programs

Below there are examples of finished programs, each consists of a single task file. To run the sample on the EM-481 it is necessary:

- 1) Create a text file (with the extension ".txt") with program text.
- 2) Put the file in the folder "TASKS".
- 3) Put the prepared folder to the memory microSD card, formatted in FAT or FAT32.
- 4) Put the memory card in the EM-481.

3.1. Example 1

This example describes a program that in the event of fault of the device will send SMS with warning. In the text 3 – MODBUS ID of the device is OM-310; 240 – is the register address which is monitored for the fault.

```
# SMS sending when bit 0 of register 240 of device 3 is set
!META
#9th version of Protocol
*PROTOCOLVERSION 9
#program run will be fulfilled every 3 seconds
* UPDATE 3
#in case of error of the parameter reading, it will be read again 2 times
* PARAMRETRIES 2
#limit of response waiting for MODBUS query is 1000 msec = 1 sec
* PARAMTIMEOUT 1000
#after each query the delay is added, equal to the response waiting time,
#so the other clients can perform their queries
* PARAMLOADRATIO 50

!DEVICES
#EM-481 can read and record no less than 120 registers per one query
#note the second character * - it is MODBUS ID of the EM-481 device
* * WRHANY 120 120
#OM-310 has MODBUS ID equal to 3 and allows reading 4 registers per one query,
#but to record only one register per one query
* 3 WRHSINGLE 4

!PARAMS
#during each updating, it is required to read the storage register with address
240,
#from the device with MODBUS ID equal to 3
#UIN16 - means that the 16-bit value and unsigned one (it can't be less than 0)
```

```
0 3 UINT16 H 240

!VARS
#copy zero bit of the register 240
#now in the variable the parameter value is 240.0
0 PARAMBIT P0 0
!CONDS
#variable V0 is compared with 1, condition is met, if V0 = 1
0 VAREQVAL V0 1
#condition is met, if the previous condition is not fulfilled and vice versa
1 NOT C0

!STRS
#SMS text
0 OM-310 (3) - avaria

!PHONES
#below the phone to receive SMS can be specified
0 01234567

!ACTS
#send SMS
0 SENDSMS H0 S0

!REACTS
#if the condition C0 is met (if 240.0 = 1), then send one SMS
* C0 ACT A0

#END - comment at the file end or blank line for correct reading
```

3.2. Example 2

In this example, the program controls the hysteresis value on the second channel of the TR-101 device, depending on the temperature on the sensor of the first channel. In the text 16 – MODBUS ID of the device is TR-101; 4 - address of the channel temperature register 1; 47 is the address of register for the hysteresis of the second channel.

The program uses registers in the field of current user settings 5500-5749. Registers 5500 and 5501 are reserved for the values respectively of the lower and upper temperature limits and the registers 5502 and 5503 are for the hysteresis value to be set in TR-101 if achieving the temperature respectively the lower or upper limits. These registers are read-only. To change them, you should be in configuration mode (see it. 5.3.4), then write the desired values to addresses of the respective editable settings. These addresses are obtained by subtracting 250 from the address current value. Thus, temperature limits are recoded into the registers 5250 and 5251, and the hysteresis – 5252 and 5253. Then, in order for the changes to take effect, you need to give the commands "Save" and "Apply" (for example by writing 4 to the register 120).

```
!META
* PROTOCOLVERSION 9
#program will run every 20 seconds
* UPDATE 20
* PARAMACTUAL 0
* PARAMLOADRATIO 50

!DEVICES
* * WRHANY 120 120
#TP-101 has MODBUS ID as 16 and can read no less than 100 registers per a query,
#but to record by one register per one query
* 16 WRHSINGLE 100

!PARAMS
#INT16 - registers with sign, as the temperature can be less than 0
0 * INT16 H 5500
1 * INT16 H 5501
2 16 INT16 H 4
#UINT16 - as the hysteresis is no less than 0
3 * UINT16 H 5502
4 * UINT16 H 5503
```



```
5 16 UINT16 H 47

!VARS
#lower and upper temperature limits, as well as its current value
0 PARAMVAL P0
1 PARAMVAL P1
2 PARAMVAL P2
#hysteresis for temperatures is lower (or above) than the appropriate limits
3 PARAMVAL P3
4 PARAMVAL P4
#current hysteresis value
5 PARAMVAL P5
!CONDS
# was the temperature out of the limits?
0 VARLEVAR V2 V0
1 VARGEVAR V2 V1
# in other cases - do not change the hysteresis (current value)
2 CONDIS 1
!VARS
# the desired hysteresis is selected from V3 - V5, according to the conditions of
C0 - C2
6 VARSELBYC V3 C0
!CONDS
# is hysteresis not set to the desired value yet?
3 VARNEVAR V5 V6
!ACTS
# write a new hysteresis in TP-101
0 PARAMWRVAR P5 V6

!REACTS
* C3 REPEAT A0

#program is completed
```

3.3 Example №3

In this example, a program is described that reads the temperature measured by OB-215, and when the temperature exceeds -15 degrees for more than 10 minutes, sends an SMS and starts logging the temperature values. In text 11 - MODBUS ID of the OB-215 device; 6 - address of the register from which the temperature is read.

```
!META
* PROTOCOLVERSION 9
# the program will run every 15 seconds
* UPDATE 15
!DEVICES
* * WRHANY 120 120
* 11 WRHSINGLE 4
!PARAMS
0 11 UINT16 H 6
# alarm flag - temperature rise for more than 10 minutes
1 * UINT16 H 5000
# counter for a delay of 10 minutes (600 seconds)
2 * UINT16 H 5001
!VARS
0 PARAMVAL P0
1 PARAMVAL P1
2 PARAMVAL P2
3 VARADDVAL P2 15
4 VAL -15
5 VAL 600
!CONDS
0 VARGRVAR V0 V4
1 NOT C0
2 VARGEVAR V1 V5
```

```
3 NOT C2
4 AND C0 C3
5 VARNEVAL V2 0
!STRS
0 OB-215 (11) - avaria, tmp *V0* > *V4*
!PHONES
# below can be specified phone number for receiving SMS
0 01234567
!ACTS
0 PARAMWRVAL P1 0
1 PARAMWRVAL P2 0
2 PARAMWRVAL P1 1
3 PARAMWRVAR P2 V3
4 SENDSMS H0 S0
5 PARAMCOMMENT P0 S0
!REACTS
* C1 REPEAT A0
* C1 REPEAT A1
* C2 REPEAT A2
* C4 REPEAT A3
* C5 ACT A4
* C5 REPEAT A5
#END
```

**Appendix D
(recommended)**

Saving data to a memory card

1 General data

The EM-481 supports microSD compatible memory cards formatted in FAT/FAT32. Only the first volume of the card is used (the maximum usable capacity on the card is 32 GB). The card can be inserted before powering in the device or while the device is in operation.

Attention - removing a memory card while the device is in operation may result in partial or complete loss of information on it. For safe removal of the memory card see section 5.3.1.

EM-481 uses a memory card for the following actions:

- reading task files with programmable logic of work;
- logging of collected data;
- export and import of settings;
- firmware updates;
- navigation on the memory card, downloading and uploading files through the WEB-interface.

When the device is started or when a memory card is inserted, its parameters and firmware update files are checked (it may take up to 30 seconds). After that, the card can be used for other actions.

When the device is restarted, when the supply voltage drops below the value specified in the settings (p. 5.3.2, register 724), EM-481 safely ejects the memory card, saving temporary data and closing open files.

2 Reading task files with programmable logic of work

EM-481 reads task files from the "TASKS" folder and its subfolders on the memory card (see Appendix B).

3 Logging of collected data

EM-481 saves the collected data to the log in the "LOGS\TASKS" folder on the memory card. The order of data collection and conditions for logging are specified in the task files (see Appendix B). If the folder is missing, it will be created. For each month, a subfolder is created with a name in the format:

«YYYY_MM»,

where

YYYY – year;

MM – month.

In this subfolder, for each day of the month, a file is created with the name in the format:

«YYMMDDII.EEE»,

where

YY – the last two digits of the year;

MM – month;

DD – day of the month;

II – index. The data is appended to the end of the current file. A new file with the next index is created when the file is filled up to the maximum size (specified in the settings, from 1 KB to 64 MB, see p.5.3.2, register 726), in case of an error writing to the file, removing the memory card or restarting the device. Before creating the file, the presence of files in the subfolder with names for the given day of the month is checked, and the maximum occupied index is found. Files are numbered starting from **01**. The first **99** indices are numeric. After **99** indices follow **A0 ... A9, AA ... AZ, B0 ... ZZ**. In total, up to 1035 indexes can be used for one day of the month, after which the recording can be suspended until the date changes (the beginning of the next day);

EEE - file extension "CSV" or "DAT" (depending on settings, see p.5.3.2, register 725).

In the event of write errors, data remains in the write queue in temporary memory, and write attempts continue until the data is written or remains in the queue for more than 10 minutes. After that, the data is removed from the write queue, while the number of bytes that could not be written is added together, and this information about losses can be added to the log later.

3.1 Logging to data bytes files

When the byte log format is selected, the EM-481 saves the collected data in a compact form to files with the "DAT" extension. Records of a fixed size of 16 bytes are appended to the files. Each record can contain the value of one parameter or a service message. The service record format is described in Table G.1. The parameter recording format is described in Table G.2.

Table D.1 - Format of the service record in the log data bytes file

Bytes	Field	Range of values	Description
0–3	Time mark	0 – 4294967295	Number of seconds since midnight 1.01.1970 UTC+00
4–7	Service record code	4294967295	Indicator for distinguishing from other types of records
8–11	Message type	0	0 – losses due to repetitive errors
12–15	Message	0 – 4294967295	For loss reporting - the number of bytes

Table D.2 - Format of parameter recording in the log data bytes file

Bytes	Field	Range of values	Description	
0 – 3	Time mark	0 – 4294967295	Number of seconds since midnight 1.01.1970 UTC+00	
4	Parameter type	0–19, 128–147	Bits	Value
			0 – 6	Parameter type index: 6 - parameter in the bit table (flags and digital inputs); other values - in the register table (storage and input), see Appendix B, table B.4.
			7	0 - parameter from the table for reading and writing (flags, storage registers); 1 - parameter from the table is read-only (discrete inputs, input registers)
5	Device ID	1 – 247	Device address from which the data was received	
6 – 7	Parameter address	0 – 65535	The address on the device where the data was read	
8 – 11	Parameter value	-2147483648 – +2147483647	The value converted to a signed 32-bit integer	
12 – 13	First register read	0 – 65535	Data read from the device before being converted to a parameter value	
14 – 15	Second register read	0 – 65535	Used for parameter types that occupy two registers	

Table D.3 - Format of records in the file of text tables of the log

Bytes	Field	Range of values
1	Date	Date when the parameter value was received
2	Time	Time when the parameter value was obtained (in the time zone of the device)
3	Parameter value	The value converted to a signed 32-bit integer
4	Date type	Text entry of the type similar to that used in the task file (see Appendix B, table B.4)
5	Parameter address	The address on the device where the data was read
6	Register table	One symbol representing a table on the device: H – storage registers; I – input registers; D – discrete inputs; C – flags.
7	Identifier	Device address from which the data was received
8	Data losses	The number of bytes that could not be written and that were removed from the write queue before creating this record. 0 - no losses
9	Comment	An empty field or comment line if the entry was created by a logging command with a comment. It is not recommended to include the table field separator character in the comment

3.2 Logging to text table files

In a case of select the tabular format of the log, EM-481 saves the collected data in text form to files with the "CSV" extension. Records are added to the files in the form of text strings consisting of fields of variable length, separated by the character selected in the settings (see p.5.3.2, register 727). Lines are separated by a standard pair of characters (CR + LF for line feed). The maximum record length without adding a comment to the end of the line is 70 bytes. When using the logging command with a comment, the maximum line length depends on the format of the comment line and can be up to 200 bytes plus the length of the values substituted into the comment. The recording format is described in Table D.3.

3.3 Filling the memory card

The time it takes for an empty memory card to be full can be calculated using the formula:

$$T_{full} \approx (V_{free} * T_{new}) / (N_{par} * L_{siz}),$$

where

T_{full} – The time it takes for an empty memory card to be full can be calculated using the formula

V_{free} – free space on the memory card;

T_{new} – update time of parameter values (see Appendix B, Table B.2);

N_{par} – the number of parameters to be logged (if the record is made with each update);

L_{siz} – the size of the log entry depending on its format.

For example:

- 1) when writing 7 parameters to the log in data byte format every 20 seconds - 2 GB card will be filled in 383479222 s (or more than 12 years);
- 2) when writing to the log in a tabular format (no comments) 3 parameters 10 times per second - the volume of 32 GB can be filled in 16361780 s (or more than 6 months).

When the logger mode is turned on (see p.5.3.2, register 725), after the free space on the memory card is exhausted, the oldest files can be deleted before writing new data. When the recorder mode is off, new data recording will be paused until space becomes available.

4 Export and import settings

The EM-481 can export the saved settings from the internal memory to the "**SETTINGS \ EM481SET.DAT**" file, or import the settings from this file and save them to the internal memory.

To export or import settings, enter the parameter settings (see p.5.3.3). Go to the "**Files**" tab, select the transition to "**Exported settings**". To export to a file, click the "**Export to file**" button. To import the settings back from the file, click the "**Import from file**" button.

The file can be up to 16 kB in size.

5 Firmware update

EM-481 can update the firmware (see Appendix E) with one of three files:

- «**UPGRADES\EM481FW1.DAT**»;
- «**UPGRADES\EM481FW2.DAT**»;
- «**UPGRADES\EM481FW3.DAT**».

Files can be up to 10 MB each in size.

**Appendix E
(recommended)**

WEB - interfaces

To access the device using a browser, the EM-481 expects an Ethernet connection to port 80 and HTTP transmissions. To connect in the address bar of the browser, call the IP address of the device (to display the address on the EM-481 display, see section 5.3.1). The browser displays WEB pages that allow you to read the status of the device, set parameters, call MODBUS functions and perform file operations on the memory card.

In addition, the HTTP connection can be used by other applications to automatically invoke MODBUS functions using the API.

EM-481 supports API in two formats: JSON and XML. For example, if the IP address of the device is "192.168.0.111", then the API JSON request without parameters will look like "192.168.0.111/api.json", and the XML API will look like "192.168.0.111/api.xml" (further in the examples, each request begins with one of these lines, and this beginning is referred to as "<API call>"). An example of a response to a request is given in Table E.1. Description of the response fields is given in Table E.2.

Table E.1 - An example of a response to an API request without parameters

JSON	XML
<pre>{ "type": "EM-48x API", "version": "1.1", "device": "EM-481", "firmwareVersion": 41, "loginChallenge": "92uJzC89fQEdB62JxOW75sGtNAmA" }</pre>	<pre><ApiReply> <Type>EM-48x API</Type> <Version>1.1</Version> <Device>EM-481</Device> <FirmwareVersion>41</FirmwareVersion> <LoginChallenge>92uJzC89fQEdB62JxOW75sGtNAmA </LoginChallenge> </ApiReply></pre>

Table E.2 - Description of the fields of the response to the API request without parameters

JSON	XML	Description
(unnamed)	ApiReply	Root element of the response
type	Type	Response type (always "EM-48x API")
version	Version	Answer version
device	Device	Device
firmwareVersion	FirmwareVersion	Firmware version
loginChallenge	LoginChallenge	Secure authorization offer (see below)

To access MODBUS authorization is required, which can be done in two ways:

- 1) the unprotected password by sending an API request with a password string in the "plainpass" parameter;
- 2) with SHA-1 protection using the authorization proposal received in the "loginchallenge" field. To do this, compute the standard SHA-1 hash of the string composed of the authorization clause and password, and then send an API request with the hash string (encoded in hexadecimal or BASE-64) in the "lcanswer" parameter. For example, for the factory password EM-481 "11111" and the sentence in Table E.1, the hash of the compound string "92uJzC89fQEdB62JxOW75sGtNAmA11111" in hexadecimal form is "28457e7fc55a67bf59caf5f73e42fd168a5fe6a3".

Upon successful authorization, the device returns a response with a redirection to the session page, for example, "/1c193447/api.xml" (hereinafter in the examples "<API session call>"), where "1c193447" is the temporary session code.

If the application making the request does not support redirection, then the requests should be called with the "redirects" parameter set to "0". Table D.3 shows the response to the request "<API call? Lcanswer = 28457e7fc55a67bf59caf5f73e42fd168a5fe6a3 & redirects = 0" if it was sent after the response in Table D.1. Table D.4 describes additional response fields.

Table E.3 - An example of a response to an API request for authorization

JSON	XML
<pre>{ ... "session": "1c193447", "status": "Ready" }</pre>	<pre><ApiReply> ... <Session>1c193447</Session> <Status>Ready</Status> </ApiReply></pre>

Table E.4 - Description of the fields of the response to the API request for authorization

JSON	XML	Description
session	Session	Session code. The absence of this element means that authorization is required. Authorized requests begin with "<API session call>" with the specified code.
status	Status	MODBUS call status: "Busy" - busy, a MODBUS call is being processed. The call should be repeated without parameters to get the result or to send a new call; "Ready" - ready, a new MODBUS call can be sent.

To call MODBUS, the parameters listed in Table E.5 are used.

Table E.5 - Request parameters for MODBUS call

Parameter	Range of values	Description
mbc_uid	0-255	Destination device ID
mbc_func	1-6, 15-16	MODBUS function code. Only one value can be written for write functions, including multiple write functions (codes 15 and 16)
mbc_addr	0-65535	Register, flag or digital input address
mbc_data	0-65535	For read functions - the number of read values (from 1 to 16)
dosend	0-65535	For write functions, the value to be written
		The presence of this parameter with any value in the request makes a MODBUS call with the specified parameters

The answer to "<API session call>? Mbc_uid = 111 & mbc_func = 3 & mbc_addr = 213 & mbc_data = 3 & dosend = 1" (for the value of the EM-481 own identifier equal to the factory default "111") is given in Table E.6. Table E.7 describes additional response fields. Description of response fields for MODBUS errors and exceptions is given in Table E.8.

Table E.6 - An example of a response to an API request for a MODBUS call (reading the current time)

JSON	XML
<pre>{ "type": "EM-48x API", ... "status": "Ready", "modbusQueries": [{ "unitID": 111, "function": 3, "address": 213, "data": 3, "response": { "data": [12, 38, 25] } }] }</pre>	<pre><ApiReply> <Type>EM-48x API</Type> ... <Status>Ready</Status> <ModbusQuery> <UnitID>111</UnitID> <Function>3</Function> <Address>213</Address> <Data>3</Data> <Response> <Data>12</Data> <Data>38</Data> <Data>25</Data> </Response> </ModbusQuery> </ApiReply></pre>

Table E.7 - Description of the fields of the response to the API request for a successful MODBUS call

JSON	XML	Description
modbusQueries	ModbusQuery	MODBUS request
unitID	UnitID	Destination device identifier in the request
function	Function	MODBUS function code in request
address	Address	Address of register, flag or discrete input in request
response	Response	Reply to request
data	Data	In a request - the number of read values or a written value, in a response - read or written data.

Table E.8 - Description of the fields of the response to the API request in case of errors in the MODBUS call

JSON	XML	Description
errorInQuery	ErrorInQuery	MODBUS request error (field in request instead of response field): Query unit ID illegal - invalid unit ID; Query address illegal - invalid address; Query data illegal is an invalid value.
errorInResponse	ErrorInResponse	MODBUS response error (field in request instead of response field): Response mismatch - The accepted response does not match the request.
exceptionCode exception	ExceptionCode Exception	MODBUS exception code (field in response instead of data field). Exception MODBUS (field in response instead of data field, values are listed in table 5.2).

**Appendix F
(recommended)**

Updating of firmware

1. General

EM-481 uses the "EM481FW1.FUS", "EM481FW2.FUS" or "EM481FW3.FUS" files in the "UPGRADES" folder on the SD memory card formatted in FAT or FAT32 format to update the firmware (hereinafter software).

Updating one of these files can be done in the firmware update mode.

2. Transmission of files to update EM-481

To transfer the update files it is possible in two ways:

1) record files to SD card on a personal computer or other external device and put the card into the EM-481, then enter the update mode of the firmware, as shown in Table D.1;

2) if updating via WEB interface is permitted in the parameter settings, tab "Other" (see it. 5.3.3), go to the tab "Files", select the transition to "Firmware update", select the firmware file and click the button "Upload file". The file will be written to the folder "UPGRADES" with the name "EM481FW2.FUS". Then click "Program". Wait for the update (3-4 minutes).

2. Update mode of firmware

EM-481 can be set in mode of firmware updating after power supply and restart. The setting in that mode is made automatically (in case of updating failure) or manually (if the button "R" being pressed during startup). The procedure of entering in mode of updating is given in Table F.1.

Table F.1 – Entering the mode of firmware updating

No.	Step	"R" button	Display	Time	Remark
1	Initialization	Pressed		0.5 s	To cancel the updating, release "R" button during these steps
2	Stand-by	Pressed		1 s	
3	Notification about entering in mode of updating	Pressed	"Entering upgrade mode"	5 s	
4	Offer to enter the mode of updating	Pressed	"To enter upgrade mode release button"	2 s	To enter the mode of software updating, release "R" button during this step
5	Protection against incidental pressing	Pressed	–	–	Holding the button pressed will cancel the firmware updating

After manual entering in mode of updating, select the file of updating. The procedure for file selection is given in Table F.2. To cancel the updating, cut off the power supply of EM-481 or wait until automatic completion of updating mode.

Table F.2 – Selection of updating file

No.	Step	"R" button	Display	Time	Remark
1	Finding the available files		"Searching for upgrade files..."	(depends on the found files)	
2	Notification about entering in mode of updating	Released	Name and version of updating file	5 s	To select a file, press and release "R" button at this step
3	Offering all files of updating	Released	–	(depends on the found files)	Repeat the step 2 for each file
4	Repeated offer	Released	–	(depends on time of step 4)	Repeat the steps 2-3 for 3 times
5	Protection against incidental entering in the mode of updating	Released	–	–	The file cancelation cause the escape from the mode of firmware updating

At automatic entering into the mode of firmware updating or at manual selection of file, the updating is made from the file. The procedure of updating is described in Table F.3.

Table F.3 – Updating of firmware

No.	Step	“R” button	Display	Time	Remark
1	Start of updating	–	“Upgrading Firmware”	2 – 10 s	
2	Firmware updating	–	(performance line shows the process of updating)	(depends on the file of updating)	Time until the end of process of updating is shown on the display.
3	Updating is successfully completed	–	“Firmware upgrade success”	5 s	
4	Startup of firmware	–	–	–	

The errors detected during the updating process are shown on the display. The possible errors during the updating of firmware are listed in Table F.4.

ATTENTION! IF THERE ARE CRITICAL ERRORS DURING THE UPDATING MODE THE OPERATION OF THE EM-481 DEVICE IS NOT POSSIBLE.

In this case the indication of a critical error is made during an hour, after that the EM-481 device automatically restarts. If an error is as a result of incidental event, the firmware will be restored from the file on the memory card.

Table F.4 – Codes of warning in firmware updating mode

Code	Warning	Actions	Remark
2	Firmware cannot be started	Initialization of mode of emergency updating: Auto start of updating from the selected file or from the first available file (if any)	The warning is as a result of other error and is automatically corrected with the help of available files of software updating
3	Error while current process of firmware updating	Similar to No.2, but the file with an error has less priority	The error is automatically corrected with available files of updating
4	The files of updating are not available	Escape from the mode of updating, start of available firmware	EM-481 device can continue operation but for reprogramming the file of updating should be loaded in the folder «UPGRADES» on the device SD memory card
5	Emergency mode - firmware cannot be started	Waiting for manual restart of device or restart automatically in 1 hour	The error is a result of three-time entering in emergency mode as a result of other errors. The correct file of firmware updating should be loaded in the folder «UPGRADES» on the SD memory card. If the error is repeated, contact the manufacturer.
6	Emergency mode - error during the current firmware updating	Waiting for manual restart of device or restart automatically in 1 hour	The error is a result of three-time entering in emergency mode as a result of other errors. The correct file of firmware updating should be loaded in the folder «UPGRADES» on the SD memory card. If the error is repeated, contact the manufacturer.
7	Unrecoverable error - no available files of updating, the firmware cannot be started	Waiting for manual restart of device or restart automatically in 1 hour	The error is a result of three-time entering in emergency mode as a result of other errors. The correct file of firmware updating should be loaded in the folder «UPGRADES» on the SD memory card. If the error is repeated, contact the manufacturer.

