

**UNIVERSAL SINGLE-PHASE INDUCTION
ELECTRIC MOTOR PROTECTION UNIT
WITH THE POSSIBILITY OF SOFT START**

UBZ-115



OPERATION MANUAL

CONTENTS

Warning	3
Introduction	3
1. Application	3
2. Technical specifications and operating conditions	3
2.1. Main technical specifications	3
2.2. Operating conditions	4
3. Construction and operating principle	4
3.1. Construction of UBZ-115	4
3.1.1. Construction	5
3.1.2. Indication and operating controls	5
3.2. Operating principle	6
3.2.1. Operating principle	6
3.2.2. Measured and computed parameters	7
3.3. Protection functions	7
3.3.1. Types of protection	7
3.3.2. Maximum current protection	8
3.3.3. Minimum current protection	8
3.3.4. Voltage protection	9
3.3.5. Delayed start and rotor lock-up protection	9
3.3.5.1. Delayed start	9
3.3.5.2. Rotor lock-up	9
3.3.6. Maximum mains frequency protection	9
3.3.7. Minimum mains frequency protection	9
3.3.8. Heat overload protection	9
3.4. Soft start	10
4. Maintenance and safety precautions	11
4.1. Safety precautions	11
4.2. Maintenance procedure	11
5. Connection of UBZ-115	11
5.1. General provisions	11
5.2. Unit connection	12
6. The Use of UBZ-115	13
6.1. General data	13
6.2. Operation of UBZ-115 before motor engagement	13
6.3. Operation of UBZ -115 after emergency motor shutdown	14
6.4. Operation of UBZ -115 after motor start	14
6.5. UBZ-115 and remote control (water level sensor) by external input.	15
7. Programming	15
7.1. General data	15
7.1.1. Full list of programmable parameters	15
7.1.2. View of changeable and computed parameters	17
7.1.3. Changing parameters of UBZ-115	17
7.1.4. Reset of factory settings	17
7.2. Programming procedure	17
7.2.1. Setting of rated current of the motor	17
8. Completeness	18
9. Terms of service and storage, and manufacturer's warranty	18
10. Transportation	18
11. Acceptance certificate	18
12. Information on claims	19
Appendix A. Dependent time delay current based protection types	20

WARNING

Before using this product, carefully read the instruction manual.

To prevent the risk of fire or electric shock, avoid falling into the water and the unit of the device under conditions of high humidity.

The unit contains high voltage components, so do not attempt to open and repair the device.

When moving from a cold to a warm location or, conversely, the details of the device can cause condensation that can cause undesired operation. In this case, before connecting the device to the mains keep it within two hours of operating conditions.

Never use abrasive materials or organic substances (alcohol, gasoline, solvents, etc.) to clean the device

Subject to the rules of operation of the device is safe to use.

INTRODUCTION

This operation manual is for the maintenance staff to familiarize with the unit, its operating principle, construction, operation and maintenance procedures of the Universal Single-Phase Induction Electric Motor Protection Unit – UBZ-115 (hereinafter referred to as “the unit”, “UBZ-115” or “the UBZ-115 unit”).

Terms and abbreviations:

- AR – Automatic reset;
- Motor – Single-phase induction electric motor;
- MCB – Miniature circuit breaker;
- Display – seven-segment three-digit LED indicator.

1 APPLICATION

The Universal Single Phase Induction Electric Motor Protection Unit UBZ-115 is a microprocessor unit.

UBZ-115 provides protection to single-phase induction electric motors with power up to 5.5 kW (25A).

The UBZ-115 unit is designed to provide permanent control of mains voltage parameters and current effective value, which is consumed by the 230V/50Hz motor.

In the UBZ-115 provides an external input for remote start or stop the motor, and feature "soft start" the motor up to 5 seconds.

UBZ-115 provides protection in the following situations:

- ✓ when the mains voltage is of poor quality (over & under voltage);
- ✓ mechanical overloads of the motor (over current);
- ✓ when motor torque is lost ("dry stroke");
- ✓ delayed start or rotor jamming;
- ✓ thermal overload (thermal model of the motor).

For each separate type of fault, the unit allows to enable or disable an automatic reset (AR) of the motor.



Before engaging the UBZ-115 unit and the motor, controlled by it, it is strongly recommended that one should learn the information from the operation manual. Failure to meet this requirement may cause serious injury of staff and damage to the equipment.

2 TECHNICAL SPECIFICATIONS AND OPERATING CONDITIONS

2.1 The main technical specifications are provided in the Table 1.

Table 1

Rated single phase supply voltage, V	~230
Minimum/maximum functional voltage, V	130 – 300
Protection against current overload (currents greater than 40A)	yes
MCB (Miniature Circuit Breaker), A	32 (class B)
Mains frequency, Hz	48 – 62
Maximum load capacity, kW	5.5
Rated current, A	25
Maximum allowable start current, A	40
Trip threshold accuracy for current, ≤, % of rated current	3
Trip threshold accuracy for voltage, ≤, V	3
Hysteresis return on voltage, ≤, V	4
Data storage term, years, not less than	10
Current consumption (at 220 V), ≤, mA	200

Weight, ≤, kg					2.6
Overall dimensions, mm					252 x 188 x 125
Remote control (water level sensor) input					Clean contact
Motor control through					Relay 40A, 240V Triac 40A, 800V
Output connections starting capacitor					Triac 40A, 800V
Device allocation					Control equipment and distribution
Typical operation					Continued
Device level protection					IP30
Index protection of electrical shock					0I
Climatic modification					UHL3.1
Permissible degree of pollution					II
Overvoltage category					II
Nominal voltage of isolation, V					450
Rated impulse withstand voltage, kV					2.5
Selectable space position					-----
The relays output terminals specification					-----
Cos φ	Max. current for U~ 240 B	Max. power	Max. voltage ~	Terminals material	-----
1.0	40 A	7200 VA	240 V	AgSnO	-----
Commutation resource of output terminals: - electrical resource 40A 240V AC, times, not less than - mechanical resource, times, not less than				100 thousand 10 million	-----

2.2 Operating conditions

The unit is designed for operation in the following conditions:

- ambient temperature is from minus 25 to +55 °C;
- storage temperature is from minus 45 to +70 °C;
- atmospheric pressure is from 84 to 106.7 kPa;
- relative air humidity (at 35 °C) is 30...90%.

3. CONSTRUCTION AND OPERATING PRINCIPLE

3.1 Construction of UBZ-115

Matching of the display symbols with the letters of Latin alphabet is shown in figure 1.



Figure 1. Matching of the display symbols with the letters of Latin alphabet

3.1.1 Construction.

The unit is structurally placed within a metal housing (252 x 188 x 125), designed for mounting on the walls. The outline of the housing with overall mounting dimensions is shown in figure 2.

Figure 2 Overall unit dimensions

3.1.2 Indication and operating controls



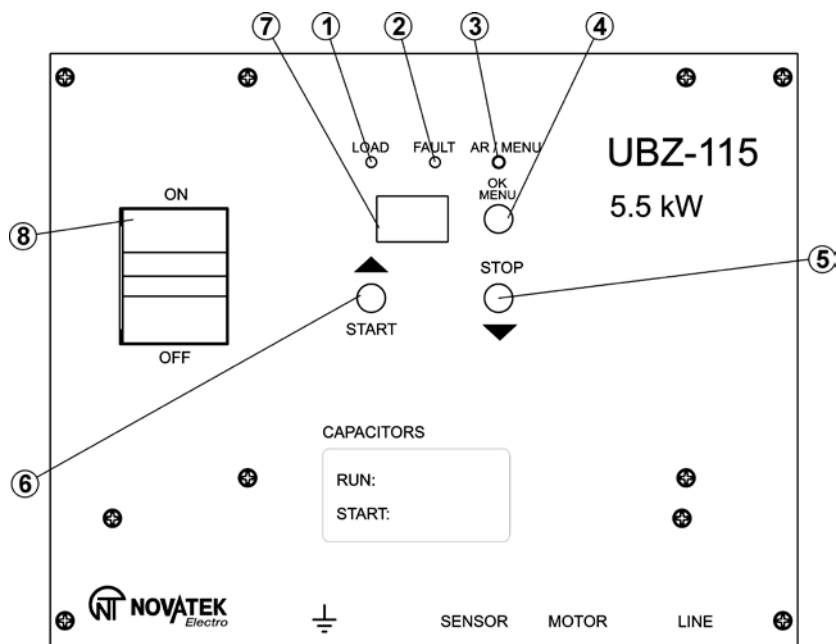

















The external view of the faceplate of the UBZ-115 unit is shown in figure 3.



- 1 – motor power-on indicator (blinking when the motor is started, shines when the motor is working, flashes when the motor is stopped by external input);
- 2 – emergency indicator (shines, if there is a failure);
- 3 – AR count and MENU mode indicator (blinks, when AR count is taking place, flashes when the time AR is completed and the AR allowed, shines, when a user has entered the menu);
- 4 – programming mode and parameters input approval button;
- 5 – STOP button in the programming mode is down;
- 6 – START button in the programming mode is up;
- 7 – seven-segment three-digit LED indicator (display);
- 8 – miniature circuit breaker (MCB).

Figure 3 Faceplate of UBZ-115

The unit control is performed the following way:

- to start the motor - press ;
- to shut down the motor - press ;
- to reset all failures – press the  button and hold for 7 seconds;
- to enter the parameters changing mode – press the  button and hold for 7 seconds; after that the AR/MENU indicator should be activated (figure 3 pos.3);
 - parameters changeover -   buttons;
 - to enter a parameter –  button;
 - to save the changed parameter –  button;
 - to escape without saving – simultaneously press  + ;
 - to escape a menu – simultaneously press  + ;
- to view the measured and computed parameters – press  button once;
 - parameters changeover -   buttons;
 - to enter a parameter –  button;
 - to escape a parameter –  button;
 - to escape a menu – simultaneously press  + ;
- if any of the buttons has not been pressed for 20 seconds, UBZ-115 will show the sign  (within 1 second) and will turn to reset state.

3.2 Operating principle.

3.2.1 Operating principle.

While operating, UBZ-115 performs permanent measuring and control of mains voltage and the current, consumed by the motor; on the basis of the received results the heat model of the motor is determined. On parameters' exceeding the allowable limits, UBZ-115 shuts down the motor and starts it again (after AR time), provided that the parameters returned to their normal value and AR enabled.

UBZ-115 does not need any additional power supply – the control voltage is at the same time the supply voltage.

UBZ-115 can operate in two modes – “manual” and “automatic”.

If “ $\bar{n} \bar{c} . r = 2$ ” motor is turned on and off by an operator, from the front panel of the device. UBZ-115 turns off the motor if the parameters go beyond the tolerance limits.

If “ $\bar{n} \bar{c} . r = 0$ ” motor is turned on and off by UBZ-115 itself, after ARC time (or 2 seconds if $\bar{n} \bar{c} . r = 1$) after voltage supply. UBZ-115 turns the motor off if the parameters go beyond the tolerance limits and will turn it on again (after ARC time) when the parameters go back to the norm.

Depending on the established parameter “ $\bar{n} \bar{c} . P$ ” external input for turning the motor on and off can be used, for example, for controlling the level of water:

- If “ $\bar{n} \bar{c} . P = 0$ ” – external input is disconnected;
- If “ $\bar{n} \bar{c} . P = 1$ ” – closure of contacts will turn on the motor, and their breaking will turn it off.
- If “ $\bar{n} \bar{c} . P = 2$ ” – breaking of contacts will turn on the motor, and their closure will turn it off.

While starting the motor, the soft start function can be applied on the basis of the phase method of adjusting (up to 5 seconds).

The soft start allows to decrease starting current and voltage subsidence during starting.

3.2.2 Measured and computed parameters.

The measured and computed parameters are specified in table 2

Table 2

NAME	MNEMONICS	RANGE	ACCURACY
Effective current, A	I _A	0.1 ... 150	2%
Maximum effective current value, A	I _A ^{max}	0.1 ... 150	3%
Mean value of effective current, A	I _A ^{av}	0.1 ... 150	3%
maximum value of mean current, A	I _A ^{av} ^{max}	0.1 ... 150	3%
Overload current, A	I _{Ao}	0.1 ... 150	3%
Starting current, A	I _S	0.1 ... 150	3%
Start time, sec	t _S	0.1 ... 999	0,5%
Effective voltage, V	U _A	100 ... 450	3V
Mains frequency, Hz	f _r	45 ... 65	1%
Heat balance of the motor, %	b _E	0 ... 999	
Voltage and current angle cosine	cos	0.00 ... 1.00	5%
Total power, kVA	P _{oF}	0.00 ... 99.9	5%
Active power, kW	P _{oA}	0.00 ... 99.9	5%
Reactive power, kVAr	P _{oR}	0.00 ... 99.9	5%
AR time, sec	t _{AS}	0 ... 999	1 sec
Operation time before heat shutdown, sec	t _{ob}	0 ... 999	1 sec
Latency time after heat shutdown, sec	t _{Eb}	0 ... 999	1 sec
*External input status	inP	ON ... OFF	

*Corresponds to the active state of the external input, depending on the setting of a parameter $\bar{n} \in P$.

3.3 Protection functions.

We do not recommend exceeding the supply voltage of over 420V for more than two hours.

In the UBZ-115 provides overvoltage protection network. The load is automatically switched off after reaching a threshold voltage higher than 310V. The accident message is shown at the display E.U_o (in excess of the maximum voltage). Restarting after the restoration of normal stress is possible only with the front panel.

Also in the UBZ-115 provides for protection of power components of the over current device. If you exceed the load current above 40A, the load will automatically switch off.

UBZ-115 detects motor current when the load relay is switched off In this case, the display shows the alarm message and E. I_o device is locked up until the alarm stops.

In the event of an accident caused by an overload of the current message is displayed and the unit is locked at the time of 60 seconds. Only after this time you can re-start the motor from the front panel.

3.3.1 Types of protection.

UBZ-115 performs the following types of current protection:

- maximum current;
- minimum current (“dry stroke”);
- maximum phase voltage;
- minimum phase voltage;
- delayed start and rotor lock-up;
- maximum mains frequency;
- minimum mains frequency;
- according to thermal overload.

3.3.2 Maximum current protection.

The protection has a time delay. It can be independent (constant), or dependent **SIT** - reverse dependent; **VIT** or **LTI** – very reverse dependent; The tripping curves are displayed in Appendix A.



Figure 4 Principle of protection with an independent time delay.

When independent time delay protection is activated, the motor is shut down, if the current, consumed by it, has exceeded the preset I_s during the time T (parameter $t_{\bar{n}t}$).

$$I_s = \bar{n}_S * I_n d, \text{ where:}$$

\bar{n}_S – tripping ratio;

$I_n d$ – motor rated current;

$t_{\bar{n}t}$ – protection tripping delay time.

Example. When $\bar{n}_S = 4.0$, $I_n d = 10$, $t_{\bar{n}t} = 10.0$, the motor will shut down within 10 seconds after the current, consumed by the load, exceeds 40 amperes..

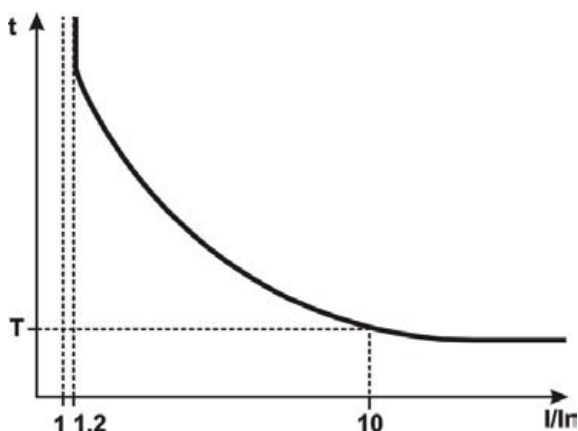

Figure 5 Principle of protection with a dependent time delay.

The operation of the dependent time delay protection conforms to IEC 60255-3 and BS 142 standards.

$I_n d$ corresponds to parameter $I_n d$ (motor rated current).

T corresponds to parameter $t_{\bar{n}t}$ (protection time constant). The time constant T is computed on the basis of $10 * I_n d$.

Example. When $I_n d = 10$, $t_{\bar{n}t} = 10.0$, the motor will shut down within 16,7 seconds, when the consumed current equals 40 amperes.

3.3.3 Minimum current protection.

The protection starts functioning, when the current, consumed by the motor, decreases less than the tripping threshold (parameter $I_n S$), and shuts the motor down, when the time of the decrease is less than the preset one (parameter t_{nT}).

The protection is not active, when the current, consumed by the motor is less than 10% $I_n d$ (parameter $I_n d$), when the current decrease is caused by the motor shutdown, but not the decrease of its load).

The protection has its own independent AR time delay (parameter t_{nA}).

In case of accident, the automatic reclosing the motor will occur:

- after the delay time t_{nA} , provided that $t_{nA} > A S t$ and AR allowed;
- after the delay time $A S t$, provided that $t_{nA} < A S t$ and AR allowed;

If the prohibited AR ($A S r = 0$), auto-reclosing the motor will not.

When using the soft start (parameter $S t.P=1$), the protection is blocked at the time of soft start ($S S t$) and start to operate after it completion.

3.3.4 Voltage protection.

Before starting the load, UBZ-315 checks the tripping thresholds and, depending on their value, either allows or prohibits the motor start. After starting the motor, the voltage control is preserved, but the shutdown decision is made on the basis of the currents.

Voltage protections include:

- Maximum phase voltage (it trips if mains voltage exceeds the threshold value (parameter $U_{\bar{n}S}$) within the time, specified by the parameter $U_{\bar{n}t}$);
- Minimum phase voltage (it trips if mains voltage decreases less than the threshold value (parameter U_{nS}) within the time, specified by the parameter U_{nt}).

3.3.5 Delayed start and rotor lock-up protection.

The principle of the delayed start and rotor lock-up protection is shown in figure 3.5.

3.3.5.1 Delayed start.

On starting the motor, the protection trips when the current, consumed by the motor, exceeds the threshold value I_s (parameter L_{LS}) within the period of time, which is more than ST (parameter L_{Lt}).

3.3.5.2 Rotor lock-up.

After motor starting is complete (the consumed current is less than 1.2 of the rated current), UBZ switches to control of possible rotor lock-up. The protection trips when the consumed current is more than the threshold value I_s (parameter L_{LS}) within the period of time, which is more than LT (parameter L_{Lt}).

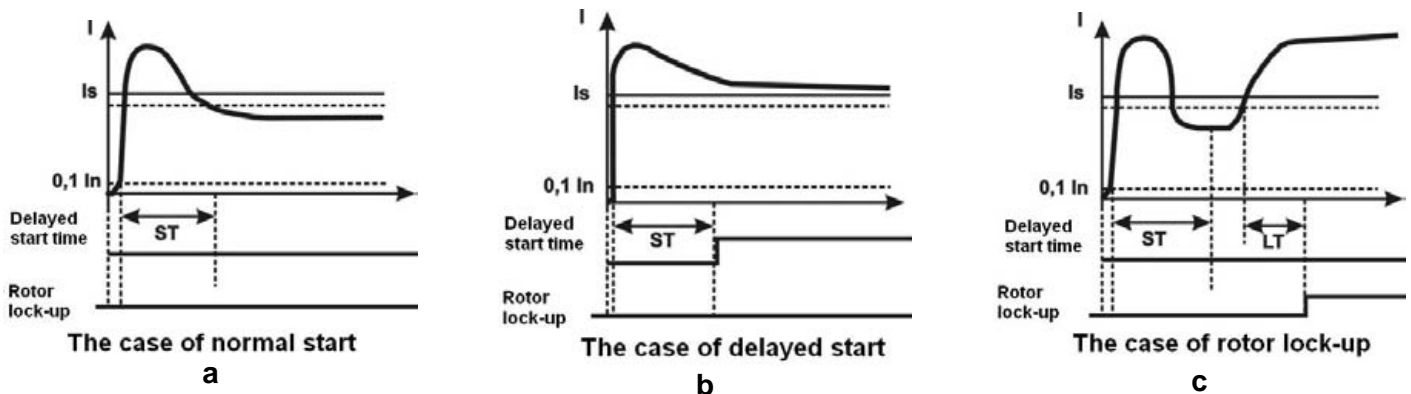

Figure 6 Delayed start and rotor lock-up.

3.3.6 Maximum frequency protection.

The motor will shut down, when the value of the mains supply frequency exceeds the threshold value (parameter $F_{\bar{n}S}$) within the period of time, which is more than the $F_{\bar{n}t}$ parameter value, and will start again, when the mains supply frequency becomes less than the threshold value (parameter F_{nS}).

3.3.7 Minimum frequency protection.

The motor will shut down, when the value of the mains supply frequency decreases less than the threshold value (parameter F_{nS}) within the period of time, which is more than the F_{nt} parameter value, and will start again, when the mains supply frequency exceeds the threshold value (parameter F_{nS}).

3.3.8 Thermal overload protection (heat model of the motor).

The heat overload protection is designed on the basis of electromotor heat balance equation under the following assumptions:

- the motor was cold before first start;
- during operation the motor releases the amount of heat proportional to the square value of the current;
- after shutdown, the motor cools down exponentially.

For the protection to function one should set up the double overload tripping time T_2 (parameter b_{2t}). The current-to-time characteristic curve with different T_2 values is shown in Figure 7.

The current-time characteristic dependence shown in table 3 below is given for the standard recommended T_2 value (60 sec when double overload occurs).

Table 3

I / In	1,1	1,2	1,4	1,7	2	2,7	3	4
T	365	247	148	88,6	60	36,4	24,6	13,5

I – value of the current, consumed by the motor, A;
 In – rated value of the current (parameter $I_{n\ d}$), A;
 T – tripping time at double overload, sec.

Cooling rotating machines is more effective during operation, rather than at time of motor stall, that is why b_{25} parameter, which is the cooling constant increase rate, during motor stop is introduced.

After load relay deactivation at thermal overload with AR permitted, the relay will get activated again after the time period that is longer than:

- thermal hysteresis time, i.e. the motor must cool down 66% of the accumulated heat;
- AR time.

By means of suitable selection of different AR values, considering thermal hysteresis, one can reduce number of starts per time unit, because the unit records heat amount that is released at the start of the motor and will lock up starting of an overheated motor.

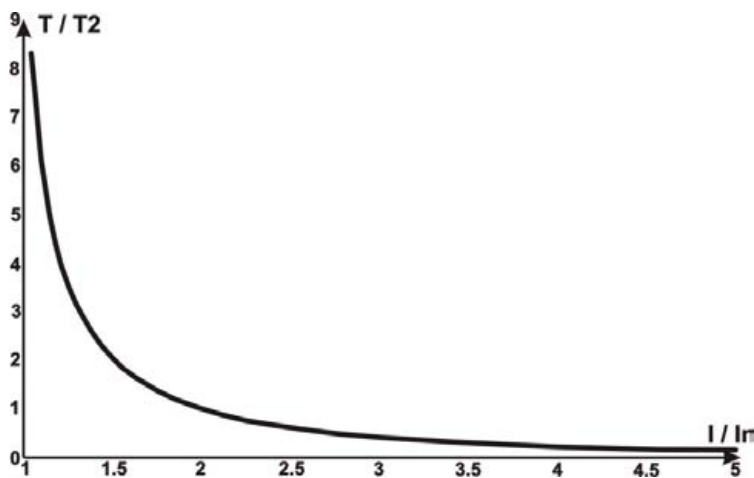

Where:

- I / In – current ratio relative to the rated current;
- T / T2 – actual trip delay time relative to T2 (double overload tripping time).

Figure 7 Current-time characteristic dependence.

3.4 Soft start.

In UBZ-115, the soft start is applied on the basis of the method of phase adjusting.

Application of soft start allows:

- to decrease overload shocks by means of decreasing the starting currents;
- to decrease the probability of motor overheat;
- to prolong the motor service life;
- to eliminate jerking in the mechanical part of the drive at the moment of starting;
- to decrease the noise and vibration of the motor;
- to decrease the consumed power.

The principle of soft start functioning is shown in figure 8.

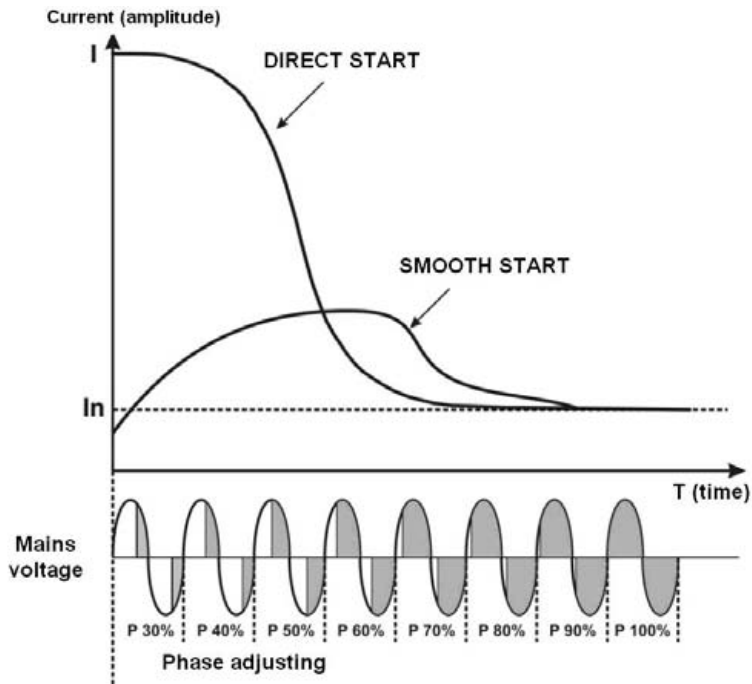

Where:

T – starting time (parameter SS_t);
 I – current, consumed by the motor;
 I_n – motor rated current (parameter IND);
 P – power of the phase regulator.
 The initial power is preset by the parameter SS_P .

Figure 8 The principle of soft start functioning.

4. MAINTENANCE AND SAFETY PRECAUTIONS

4.1 Safety precautions

- 4.1.1 Power plug-in motor must not exceed specified herein as this can cause overheating of the contact group and fire products.
- 4.1.2 In the UBZ-115 uses a life-threatening stress. When troubleshooting, maintenance, assembly work, you must disable the device and attached actuators on the network.
- 4.1.3 It is not intended for use in bumps and knocks.
- 4.1.4 Not allowed ingress of moisture to the input terminals terminal blocks and internal element device.
- 4.1.5 Do not use the device in harsh environments with content in the atmosphere, acids, alkalis, oils, etc.
- 4.1.6 Connection, adjustment and maintenance of the unit must be performed only by qualified specialists, having learned this operation manual.



Warning! When the motor is shut down, the UBZ-115 unit does not provide full isolation from electric mains, and because of that there can be mains voltage on the motor. It is prohibited to perform any kind of work without full disconnection of the unit from the mains.

4.2 Maintenance procedure

The recommended frequency of maintenance is every six months.

The maintenance procedure consists of visual inspection, during which one should check the reliability of wires connection, the absence of breaks and cracks of the unit's housing.

While performing the maintenance of the unit, one must follow all the safety precautions, specified in point 4.1.

5. CONNECTION OF UBZ-115

5.1 General provisions.

Prepare the cables for:

- connecting the unit with the motor (not less than 4 mm²);
- power supply (mains 230V/50Hz, not less than 4 mm²);
- connect the device with an external sensor (dry contact, not less than 0.75 mm²);
- connect the device with run capacitor (not less than 1.5 mm²);
- connect the device with start capacitor (not less than 1.5 mm²);
- grounding the housing of the unit (not less than 4 mm²).

In order to provide reliability of electrical connections is recommended to use cables with stranded copper conductors, before joining the ends of which should be thoroughly cleaned.

If you use the motor without built-in capacitor, for phase shift its necessary to select a suitable container capacitor to be installed directly into the UBZ-115. Approximate capacity of the phase-shifting capacitor can be obtained from the calculation of 2.5 uF per 100W motor power. Value of starting capacitor should be in 2-3 times greater than run capacitors. The operating voltage of the capacitor should not be below 400V.



Warning! Capacitors should be designed to work with electric motors.

Some capacitance ratings for a definite motor power are specified in table 4.

Table 4

Motor power kW	0,12	0,18	0,25	0,37	0,55	0,75	1,1	1,5	2,2	3,0	4,0	5,5
Crun, microfarad	3	5	7	10	15	20	30	40	60	80	100	140
Cstart, microfarad	7	10	15	25	30	40	60	90	120	170	220	310



Warning! The wires, which are subject to connection of power supply and external power equipment, are rated at the maximum voltage of 400V. In order to avoid the electric insulation breakdown, it is prohibited to connect power supplies of the voltage, exceeding the specified value. The housing of the unit must be grounded!

Figure 9 shows the scheme of mounting the device.

- 1 – Mounting holes (4 pieces);
- 2 – Start capacitor;
- 3 – Run capacitor;
- 4 – Screw M3 (4 pieces);
- 5 – Connection terminals;
- 6 – Seals cable connection PG-24 (2 pieces);
- 7 – Seals cable connection PG-11 (1 pieces);
- 8 – Washer M3 (4 pieces);
- 9 – Spring washer M3 (4 pieces);
- 10 – Screw-nut M3 (4 pieces);
- 11 – Back cover is connected;
- 12 – Grounding screw;
- 13 - *Clamp assembly.*

Figure 9 scheme of mounting the device.

5.2 Unit connection.

Depending upon the type of the used motor, connection is accomplished according to one of the following diagrams, shown in figure 10.

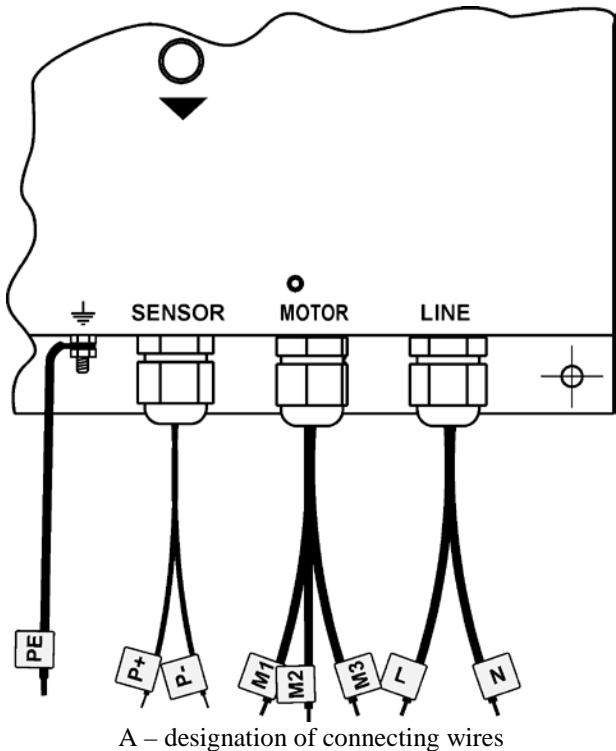

- L – Phase 230V;
- N – Zero 230V;
- M1 – common wire motor;
- M2 – run wire motor;
- M3 – start wire motor;
- P+ – input external sensor “+”;
- P- – input external sensor “-”;
- PE – ground.

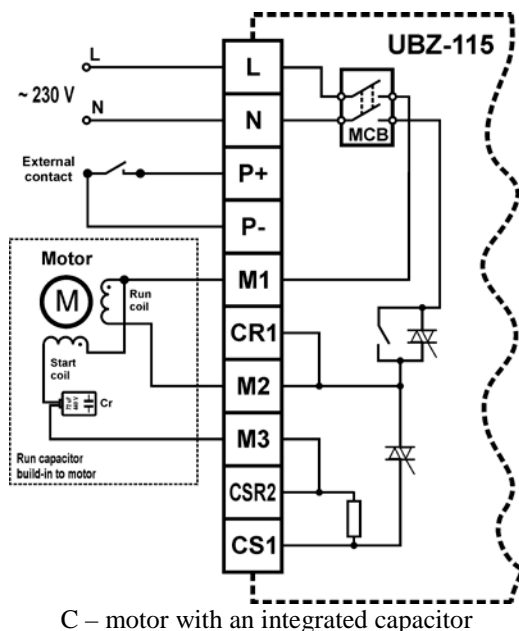
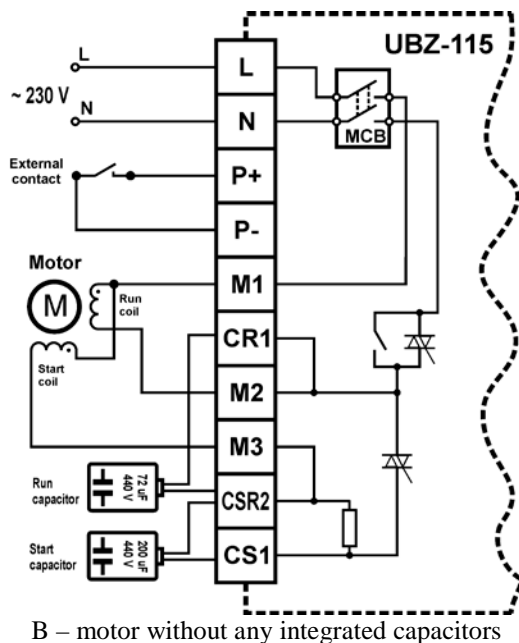

Figure 10 Motor connection diagrams.

While connecting single-phase motors with integrated capacitors, the motor is connected to wires “M1” and “M2”.

6 THE USE OF UBZ-115

6.1 General data.



Note! UBZ-115 is supplied with a set rated current equaling zero. In this case the motor will not start until the rated current of the motor is set (parameter i_{nd}).

6.2 Operation of UBZ-115 before motor engagement.

After energizing (first engagement) the before starting the motor for two seconds, the screen displays the flashing $S t A$, during this time UBZ-115 checks the quality of the mains voltage.

Depending on the value of parameter dSP the indicator displays:

- 0 – mains voltage value;
- 1 – mains frequency value;
- 2 – AR countdown.

If the mains voltage is of bad quality (over/ under), the motor will not start, and the display will show the corresponding failure code and the failure LED indicator will shine (figure 3 pos. 2).

During the AR related blinking LED "AR" (Fig. 3, Pos. 3) reached end of time, there are active alarms AR, the LED "AR" (Fig. 3, Pos. 3) starts flashing at intervals of 1.2 seconds, indicating that the disappearance of an active failure the motor will run (AR enabled).

If there are no factors, which do not allow the motor to start, the motor start will be determined by the values of parameters $\bar{n}\bar{c}.r$ (operation of the motor) and $\bar{S}\bar{t}.P$ (motor starting mode):

- $\bar{n}\bar{c}.r = 0$ – the motor will start automatically after AR time;
- $\bar{n}\bar{c}.r = 1$ – the motor will start automatically after 2 seconds;
- $\bar{n}\bar{c}.r = 2$ – the motor will start after pressing the **START** button;
- $\bar{S}\bar{t}.P = 0$ – usual starting without the soft start;
- $\bar{S}\bar{t}.P = 1$ – starting with the soft start.

While starting the motor (motor start is determined, when consumed current exceeds the 1.2 level of the rated current) the "Load" LED indicator (figure 3 pos. 1) blinks with the frequency of 4Hz. The "starting capacitor **Cstart** is connected to the start winding of the motor either for the time, specified in parameter $\bar{S}\bar{c}.t$, or until the moment of determination of the end of starting the motor (the consumed current decreased less than 1.2 of the rated current). After the end of starting the "Load" LED indicator shines constantly.

Restart (start after a stop) the motor is possible only on the expiration of the minimum time stopping the motor, this time is fixed (5 seconds), the device is intended to protect the motor from the frequent start-ups.

6.3 Operation of UBZ-115 after emergency motor shutdown.

On occurrence of any failure, the motor shuts down, the display shows the failure code (the code is displayed in turn with the value of the failure in an interval of 2 seconds) and the "Failure" LED indicator begins to shine (figure 3 pos. 2). LED indicator "Alarm" (fig. 3. pos.2) is blinking when at least one alarm is active, it is shining when active alarms are absent, but they had taken place some time ago.

In such case UBZ-115 works like it did before turning in the motor, parameter $\bar{n}\bar{c}.r$ is ignored; the motor is started after ARC time.

If the account at the end of time, there are active alarms AR, the LED "AR" (Fig. 3, Pos. 3) starts flashing at intervals of 1.2 seconds, indicating that the disappearance of an active failure the motor will run (AR enabled)"If ARC is forbidden after an alarm ($\bar{A}\bar{S}.r = 0$), it is impossible to start the motor before UBZ-115 is switched off or a button, resetting all alarms, is pushed and pressed (**STOP** more than 7 sec).

If several failures have occurred, the display sequentially shows the codes with the interval of 4 seconds.

The example of two failures display ("Minimum phase current" and "Minimum mains voltage") is shown in table 5.

Table 5

Display	E_{in}	060	E_{Un}	150	E_{in}	060
Time, sec	0	2	4	6	8	10

6.4 Operation of UBZ-115 after motor start.

UBZ-115 performs the voltage and current control. The motor shuts down on tripping of any of the protections, specified in table 6. The display shows the value of the current, consumed by the motor.

Table 6

Failure	Mnemonics	Comment
The presence of currents, when motor stopped., A	E_{i0}	
Over current, sec	E_{of}	Time lock device
Maximum phase current, A	E_{in}	
Minimum phase current, A	E_{in}	
Overvoltage, V	E_{Uo}	Voltage is greater than 310V
Maximum mains voltage, V	E_{Un}	
Minimum mains voltage, V	E_{Un}	
Maximum mains frequency, Hz	E_{Fn}	
Minimum mains frequency, Hz	E_{Fn}	

Thermal overload, %	E.b2	
Delayed start, A	E.LL	
Rotor lock-up, A	E.Lb	

6.5 UBZ-115 and remote control by external input (water level sensor).

External input can be used as a signal to turn on and off the motor if the parameter “ $\bar{n} \square P$ ” is set other than zero.

- If “ $\bar{n} \square P = 1$ ” – closure of contacts will turn on the motor, and their breaking will turn it off.
- If “ $\bar{n} \square P = 2$ ” – breaking of contacts will turn on the motor, and their closure will turn it off.

If it is allowed to turn on the motor (button “Start” is pushed (fig. 3 pos.6) or the motor starts automatically after energy supply (parameter $\bar{n} \square r = 0$ or 1)) and there is an enabling signal on the external input, the motor will be turned on.

If it is allowed to turn on the motor and there is a forbidding signal on the external input, the motor will not be turned on, at this the LED “Load” (fig. 3 pos.1) is flashing with interval 1.2 sec, indicating that when the enabling signal comes from the external input, the motor will be turned on.

7. PROGRAMMING

7.1. General Data.

Programmable parameters are preset by the user while programming and are saved in nonvolatile memory after disconnection of power supply.

7.1.1 The complete list of programmable parameters is given in table 7





Table 7

PARAMETER	MNEMONIC S	MIN./MAX.	FACTORY SETTING	ACTION
Basic parameters				
Rated current, A	ind	0.5 / 25.0	0	0 – current is not set, UBZ-115 will not enable load until current is set.
Time within which average current value is measured, sec	iQt	10 / 600	60	Time, within which the effective current value is computed (parameter ARQ).
Indication before starting the motor	dSP	0 / 2	0	0 – voltage displayed; 1 – frequency displayed; 2 – AR countdown displayed;
Password	PAS	0 / 999	123	0 – no password, any other value will activate the password.
Parameters reset	rSt	0 / 1	0	0 – no action; 1 – parameters reset to factory settings.
Version	uEr*		20	Version of program firmware of the device.
Automatic Reses (AR)				
AR time for min. current protection, sec	tAR	5 / 900	600	Delay time after tripping of the minimum current protection.
AR time, sec	ASt	5 / 900	5	Delay time before the repeated start of the motor.
Authorization of AR operation	ASr	0 / 2	2	0 – AR disabled; 1 – AR disabled for all failures, except the current ones. 2 – AR enabled for all failures.
Motor control				
Remote control start/stop	$\bar{n} \square P$	0 / 2	0	0 – remote start / stop is forbidden; 1 – START (external input is closed), STOP (external input is open); 2 – START (external input is open), STOP (external input is closed).
Fires start	$\bar{n} \square r$	0 / 2	2	Operation of UBZ-115 after its energizing. 0 – motor start after AR time; 1 – motor start after 2 seconds; 2 – motor start from the faceplate.
Motor start				
Motor starting mode	SStP	0 / 1	0	0 – usual start;

				1 – soft start;
Motor starting time, sec	50t	0.1 / 10.0	1.0	Time, for which the starting capacitor is connected.
Soft start initial power, %	55P	20 / 100	40	Initial power of soft start.
Soft start time, sec	55t	0.1 / 5.0	1.0	Soft start time.
Maximum current protection				
Protection function mode	inP	0 / 2	0	0 – protection with independent time delay; Protection with dependent time delay: 1 – SIT (reverse dependent); 2 – VIT or LTI (very reverse dependent);
Tripping ratio	inS	0.8 / 6.0	4.0	The ratio is set in relation to the motor rated current. (Active when $inP = 0$).
Tripping time, sec	int	0.3 / 600	10.0	Current protection tripping time.
Authorization of protection functioning	inr	0 / 2	1	0 – protection function disabled; 1 – protection function enabled; AR disabled; 2 – protection function enabled; AR enabled.
Minimum current protection				
Tripping setting, %	inS	11 / 90	20	Set in % of the preset motor rated current ind .
Tripping time, sec	int	0.3 / 100	5.0	Current protection tripping time.
Authorization of protection functioning	inr	0 / 2	2	0 – protection function disabled; 1 – protection function enabled; AR disabled; 2 – protection function enabled; AR enabled.
Delayed start and rotor lock-up				
Tripping setting	LLS	1.3 / 6.0	2.0	Set in relation to the rated current.
Tripping time of delayed start, sec	LLt	1 / 600	10	Protection tripping time at delayed start.
Tripping time of rotor lock-up, sec	Lbt	0.3 / 300	1.0	Protection tripping time at rotor lock-up.
Authorization of protection functioning	LLr	0 / 2	1	0 – protection function disabled; 1 – protection function enabled; AR disabled; 2 – protection function enabled; AR enabled.
Thermal overload (heat model of the motor)				
Tripping time, sec	b2t	10 / 120	60	Tripping time at double overload.
Increase ratio	b2S	1.0 / 4.0	1.0	Increase ration of cooling constant at the motor being shut down.
Authorization of protection functioning	b2r	0 / 2	2	0 – protection function disabled; 1 – protection function enabled; AR disabled; 2 – protection function enabled; AR enabled.
Maximum phase voltage protection				
Tripping voltage, V	UnS	$(UnS+10)/300$	260	Tripping voltage of protection.
Tripping time, sec	Unt	1 / 60	2	Tripping time of the voltage protection.
Authorization of protection functioning	Unr	0 / 2	2	0 – protection function disabled; 1 – protection function enabled; AR disabled; 2 – protection function enabled; AR enabled.
Minimum phase voltage protection				
Tripping voltage, V	UnS	$130 / (UnS-10)$	176	Tripping voltage of protection.
Tripping time, sec	Unt	1 / 60	10	Tripping time of the voltage protection.
Authorization of protection functioning	Unr	0 / 2	2	0 – protection function disabled; 1 – protection function enabled; AR disabled; 2 – protection function enabled; AR enabled.
Maximum frequency protection				
Tripping frequency, Hz	FnS	$(FnS+0.1) / 62,0$	51.0	Tripping frequency of protection.
Tripping time, sec	Fnt	1 / 60	10	Tripping time of the frequency protection.
Authorization of protection functioning	Fnr	0 / 2	1	0 – protection function disabled; 1 – protection function enabled; AR disabled; 2 – protection function enabled; AR enabled.
Minimum frequency protection				



Tripping frequency, Hz	F_{n5}	48,0 / ($F_{n5}-0.1$)	49.0	Tripping frequency of protection.
Tripping time, sec	F_{nt}	1 / 60	10	Tripping time of the frequency protection.
Authorization of protection functioning	F_{nr}	0 / 2	1	0 – protection function disabled; 1 – protection function enabled; AR disabled; 2 – protection function enabled; AR enabled.
* - parameter is available only for view.				





7.1.2 View of changeable and computed parameters.

In order to view the changeable and computed parameters, one should press the  button once; after that the display will show the first parameter from table 2. Selection of parameters is performed by pressing the   buttons, view – the  button, escape view – the  button. If any of the buttons has not been pressed for 20 seconds, UBZ-115 will turn to reset state.

7.1.3 Changing parameters of UBZ-115.



In order to change parameters, one should press the  button and hold it for 7 seconds. Herewith:

- If there has been set a password, one should enter it. Changing the value - the   buttons, confirmation of the password - the  button. Cancellation of the entered password - if any of the buttons has not been pressed for 20 seconds, UBZ-115 will turn to reset state.
- If the entered password is correct, the “AR/MENU” LED indicator will shine (figure 3 pos. 3) and the display will show the first parameter from table 7.
- If the entered password is not correct, UBZ-115 will turn to reset state.
- If parameter PAS is not set to “0”, checking of the passport will not be performed. the “AR/MENU” LED indicator will shine (figure 3 pos. 3) and the display will show the first parameter from table 7.

Selection of parameters is performed by pressing the   buttons, recording of a parameter and returning to menu - the  button, returning to menu without recording – the  +  buttons. If any of the buttons has not been pressed for 20 seconds, the unit will turn to reset state.

7.1.4 Reset of factory settings.

Reset to factory settings can be performed one of the following ways:

- In the parameters changing mode (point 7.1.3) set parameter r_{5t} to 1 and press the  button. The unit will perform the restart with the preset factory settings. In this case the password will not be reset.
- To energize the unit, while holding the   buttons simultaneously for more than 2 seconds. The display will show nRU ; after that release the buttons. After 6 seconds UBZ-115 will perform the restart with the preset factory settings, including the password (default password is 123).

7.2 Programming procedure.

To start working with UBZ-115, it is enough to set the value of the rated motor current and the mode of motor control. The other parameters, if necessary, can be changed in the process of operation.

7.2.1 Setting of rated motor current.

Set the value of parameter in_d according to the rated current of the used motor.

8 COMPLETENESS

The package UBZ-115 includes:

- | | |
|-------------------------------------|-------|
| - Universal protection unit UBZ-115 | 1 pc; |
| - Operating Manual | 1 pc; |
| - Clamp assembly 300 x 4 mm | 2 pc; |
| - The packing box | 1 pc. |

9. TERMS OF SERVICE AND STORAGE, AND MANUFACTURER'S WARRANTY

9.1 The service life of UBZ-115 is 10 years. After the service life is over, one should contact the manufacturer.

9.2 The manufacturer guarantees the failure-free operation of UBZ-115 within 36 months (3 years) from the day of purchase.

9.3 During the warranty period the manufacturer produces a free repair of the product in compliance with customer requirements specifications, rules governing the storage, installation and operation.

The product is not eligible for warranty service in the following cases:

- Completion of warranty period or period of service;
- The product shows signs of physical damage (cracks, chips, cuts, deformation, etc.) could be caused by high or low temperature, mechanical stress, fractures, falls, etc.
- The presence of traces of moisture, foreign objects, dust and dirt inside the unit (including insects), exceeding the permissible limits specified in the passport.
- Repair of products does the organization or person that does not have appropriate authorization from the manufacturer.
- Complete the product does not meet the "Operating Guide" (no sensor changes the electrical circuit, change denominations of components);
- Damage caused by an electric current or voltage values which exceed the nameplate, improper or careless handling of the product is not subject to the instructions for installation and use;
- A lightning strike, fire, flooding, lack of ventilation and other causes beyond the control of the manufacturer.

9.4 Warranty and after-sales service (at current rates) is the place of purchase;

9.5 Manufacturer's warranty does not guarantee reimbursement of direct or indirect damages, loss or damage, as well as costs associated with transporting the product to the service center.

10. TRANSPORTATION

Transportation of UBZ-115 in the container can be performed by any means of transport in accordance with the requirements and the rules of shipping and freight traffic, valid for these means of transport.

While transportation, loading and storage, UBZ-115 must be protected against strokes, jerks and impact of humidity.

APPENDIX A.

Dependent time delay current based protection types.

The diagrams are given for the constant of the protection functioning time, which equals 1 second (parameter “ T ”). When any other value of the time constant is set, the tripping time of protection changes in proportion to the time constant (for example, when “ T ”=10 seconds, the tripping time of protection at the same ratio of the currents will increase 10 times).

SIT - Reverse dependent standard time delay curve

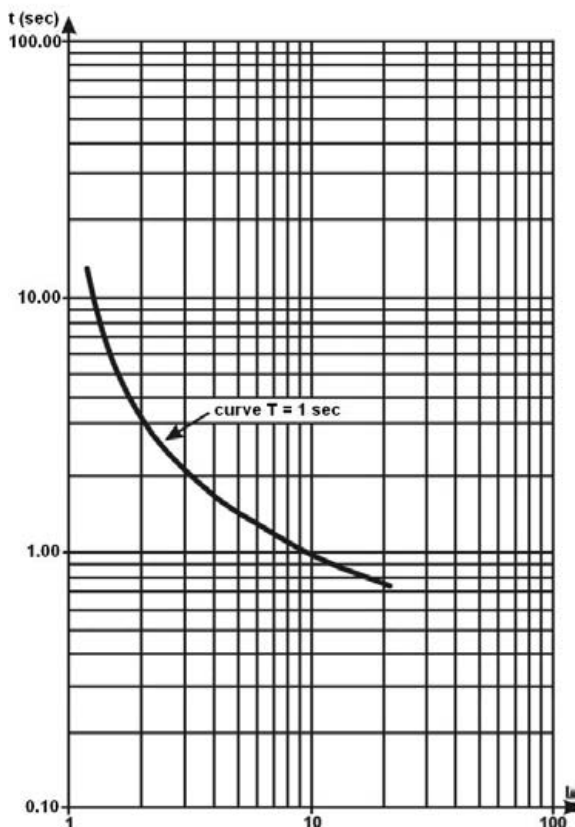

VIT - very reverse dependent time delay or LTI - lengthly reverse dependent time delay curve

