

PUMPING PLANT CONTROLLER MCK-108



OPERATING MANUAL

*Quality control system on the development and production complies with requirements
ISO 9001:2015*

Dear customer,

Company NOVATEK-ELECTRO LTD. thanks you for purchasing our devices.
You will be able to use properly the device after carefully studying the Operating Manual.
Keep the Operating Manual throughout the service life of the device.

ATTENTION! ALL REQUIREMENTS OF THIS OPERATING MANUAL ARE COMPULSORY TO BE MET!



WARNING! – DEVICE TERMINALS AND INTERNAL COMPONENTS ARE UNDER POTENTIALLY LETHAL VOLTAGE.

TO ENSURE THE DEVICE SAFE OPERATION IT IS STRICTLY FORBIDDEN THE FOLLOWING:

- TO CARRY OUT MOUNTING WORKS AND MAINTENANCE WITHOUT DISCONNECTING THE DEVICE FROM THE MAINS;
- TO OPEN AND REPAIR THE DEVICE INDEPENDENTLY;
- TO OPERATE THE DEVICE WITH MECHANICAL DAMAGES OF THE CASE.

IT IS NOT ALLOWED WATER PENETRATION ON TERMINALS AND INTERNAL ELEMENTS OF THE DEVICE.

During operation and maintenance the regulatory document requirements must be met, namely:

- Regulations for Operation of Consumer Electrical Installations;
- Safety Rules for Operation of Consumer Electrical Installations;
- Occupational Safety when in Operation of Electrical Installations.

This Operating Manual is intended to familiarize you with the design, the requirements for safety, operation and maintenance procedures of the pumping plant controller MCK-108 (hereinafter referred to as either MCK-108 or the device).

MCK-108 complies with the requirements of:

EN 60947-1; EN 60947-6-2; EN55011; EN 61000-4-2

Harmful substances in amounts exceeding maximum permissible concentrations are not available.

TERMS AND ABBREVIATIONS

List of Used Abbreviations:

EL – Emergency Level

CPG - Contact Pressure Gauge

UL – Upper Level

AR time - Automatic Reset time

LL – Lower Level

DR – Dry Run

MS – Magnetic Starter

Conduction-measuring sensor of liquid level is a sensor, the operating principle whereof is based on the increase of electrical conduction between the common and the signal electrodes, if there is liquid between them.

Contact pressure gauge (CPG) measures pressure, produced by liquid. For instance, one can determine the liquid level in the tank by measuring pressure at the bottom of a tank (an outlet pipe).

The pressure gauge used in MCK-108 must correspond to type V (must have two contacts one of which must be a break contact (closed at low pressure); the second contact must be a make one (closing at high pressure); if pressure is between the high and the low levels, both contacts must be broken).

Note - As usual, CPGs with two contacts have universal (transfer) contacts and the necessary type of CPG can be set by the user.

Filling mode - In this mode, MCK-108 controls the pump, filling the outer tank by pumping water from the well.

Drainage mode is used for pumping liquid out of the well, for instance - in sewerage stations.

Two pumps may be used in the filling mode. For balancing the wear-and-tear, the user can set the alternate operation of the pumps.

To prevent failure of the electric motor while draining the well one may use a dry run sensor (conduction-measuring dry run sensor is located in the well). After deactivation of the pump electric motor due to dry run failure, the pump activation delay is provided for the time of filling the well (the delay time is determined by the AR time (automatic reset time) parameter and can be set by the user).

1. APPLICATION

The MCK-108 is designed to create technological processes automation systems, related to control and maintaining of a set level of liquid substances in different kinds of tanks by controlling an electric motor (or electric motors) of one or two pumps.

There is no amount of harmful substances, exceeding the maximum allowable concentration.

Maintaining of a set level of liquid substances is performed:

- in case of single-phase motor with capacity of up to 1 kW - by controlling the integrated pump relay;

- in case of three-phase motor or single-phase motor with capacity of over 1 kW - by controlling the magnetic starter coil (contactor).

MCK-108 provides controlling of the electric motor (electric motors) of one or two pumps in an automated mode according to one of the algorithms integrated into the device.

MCK-108 provides working with liquids of various electrical conduction - tap water and polluted water, milk and food products (low-acid, alkaline etc.).

1.1 Controls and overall dimensions of MCK-108 are specified in figure 1.

1.2 Designation of contacts

1 – sensor "DR" (Dry Run);

2 – normally broken contact of the functional relay;

3 – normally closed contact of the functional relay;

4 – common contact of the functional relay;

5 – common contact of the pump relay;

6 – normally broken contact of the pump relay;

7, 8 – power supply;

9 – sensor "LL" (Lower Level);

10 – sensor "UL" (Upper Level);

11 – sensor "EL" (Emergency Level);

12 – common contact for sensors.

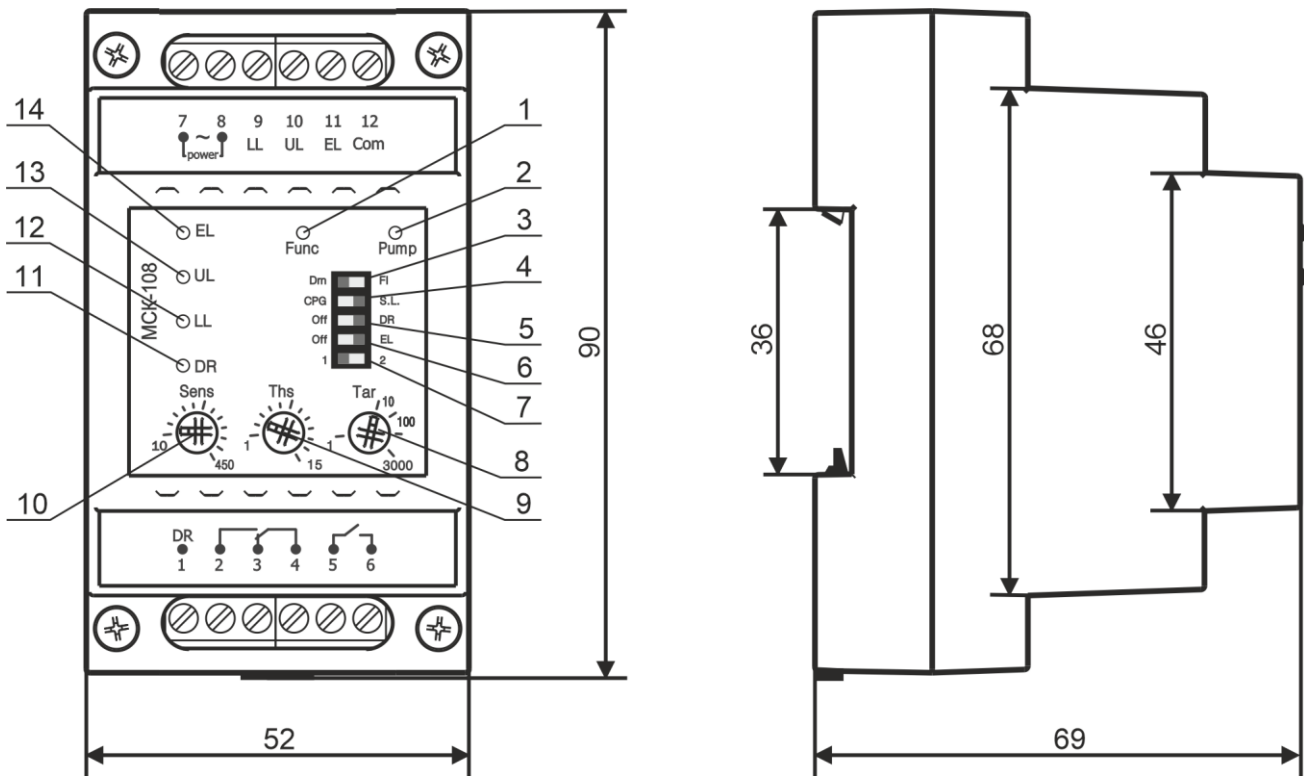

- 1 – LED **Func** (Function) glows green if the functional relay contact is closed;
- 2 – LED **Pump** glows green if the pump relay contact is closed;
- 3 – Switch **Dr – Fi** (Drainage – Filling) sets either the drainage or the filling mode;
- 4 – Switch **CPG – S. L.** (CPG – Level Sensor) sets either the contact pressure gauge (CPG) or level sensors mode;
- 5 – Switch **Off - DR** allows operation of the dry run sensor;
- 6 – Switch **Off - EL** allows operation of the emergency level sensor;
- 7 – Switch **1 – 2** sets the number of pumps in use;
- 8 - Handle **Ths** adjusts the sensor response delay time (hydraulic shock);
- 9 – Handle **Tar** adjusts the automatic reset (AR) time after failure of **DR** sensor;
- 10 – Handle **Sens** adjusts sensor resistance for various environments;
- 11 – LED **DR** (Dry Run) glows green if the liquid level is higher than the dry run sensor; glows red if the liquid level is lower than the dry run sensor; and blinks green if the liquid level is higher than the dry run sensor, but AR time has not elapsed yet; does not light up if switch **Off – DR** is in “Off” position.
- 12 – LED **LL** (Lower Level) glows green the liquid level is higher than the lower level sensor. If the liquid level is lower than the lower level sensor, in the filling mode it glows red, while in the drainage mode it blinks green;
- 13 – LED **UL** (Upper Level) glows red if the liquid level is higher than the upper level sensor;
- 14 – LED **EL** (Emergency Level) glows red if the liquid level is higher than the emergency level sensor, if the liquid level is lower than the emergency level sensor or switch **Off – EL** is in “Off” position LED does not glow.

Figure 1- Controls and overall dimensions of MCK-108

1.3 Operation conditions

- Operating temperature range – from -35 to +55 °C;
- Atmospheric pressure – from 84 to 106,7 kPa;
- Relative humidity 30 ... 80 % (at +25 °C temperature).

If the temperature of the device after transportation or storage differs from the environment temperature at which it is expected to operate, then before connection to electric mains keep the device under the operating conditions within two hours (because the device elements may have moisture condensation).

ATTENTION! The device is not intended for operation in the following conditions:

- Significant vibration and shocks;
- High humidity;
- Aggressive environment with content in the air of acids, alkalis, etc., as well as severe contaminations (grease, oil, dust, etc.).

2 TECHNICAL CHARACTERISTICS

General data for MCK-108 are specified in Table 1.

The main technical characteristics of MCK-108 are specified in Table 2.

The characteristics of the integrated relays output contacts are specified in Table 3.

Table 1 - General Data

Name	Value
Purpose of device	Control and distribution equipment
Rated operating regime	continuous
Protection class	IP 20
Electric shock protection class	II
Climatic version	NF 3.1
Allowable pollution rating	II
Overvoltage category	II
Rated insulation overvoltage, V	450
Rated impulse withstand voltage, kV	2.5
Connecting terminals wire section, mm ²	0.5 – 2
Tightening torque of terminal screws, N*m	0.4

Table 2 - The main technical characteristics

Name	Value
Rated supply voltage: single-phase 50 Hz, V	230/240
Voltage, at which operability is maintained: - minimum, V - maximum, V	130 265
Mains frequency, Hz	48 – 62
Analog Inputs: - input for connecting level sensor (of pressure) - general for level sensors (of pressure)	4 1
Main outputs: - pump relay - make contact for controlling electric motor starter – 10 A 250 V at cos φ=1, piece - functional relay – transfer contact - 10 A 250 V at cos φ=1, piece	1 1
Controlled environment resistance for conduction-measuring sensor, kilohm, not more than	450
Power consumption (under pressure), not more than, W	3.3
Weight, not more than, kg	0.2
Overall dimensions, mm	Figure 1
Installation onto standard 35 mm DIN rail	
The device preserves functionality in any position within the space	
Casing material – self-extinguishing plastic	

Table 3 - The characteristics of the integrated relays output contacts

Operating regime	Max. current at U~250 V, A	Number of trips x1000	Max. switching power, VA	Max. current at Uconst.=30 V, A
cos φ = 0.4	5	50	4000	3
cos φ = 1.0	10	100		

3 INTENDED USE

3.1 Preparation for operation

3.1.1 Preparation for connection:

- Unpack the device (we recommend to keep the original packing for the entire warranty period of the device operation);
- Check the device for damage after transportation; in case of such damages detection, contact the supplier or manufacturer;
- Carefully study the Operating Manual (**pay special attention to the connection diagram to power the device**);
- If you have any questions regarding the installation of the device, please contact the manufacturer by telephone number indicated at the end of this Operating Manual.

3.1.2 General instructions

ATTENTION! MCK-108 ARE NOT DESIGNED FOR LOAD COMMUTATION IN CASE OF SHORT CIRCUITS. THEREFORE THEY SHOULD BE PROTECTED BY AUTOMATIC CIRCUIT BREAKERS (FUSES) WITH TRIPPING CURRENT NOT EXCEEDING 10 A.

ATTENTION! ALL CONNECTIONS MUST BE PERFORMED WHEN THE DEVICE IS DE-ENERGIZED.

Error when performing the installation works may damage the device and connected devices.

To ensure the reliability of electrical connections you should use flexible (stranded) wires with insulation for voltage of not less than 450V, the ends of which it is necessary to be striped of insulation for 5 ± 0.5 mm and tightened with bootlaces. Recommended cable cross section for connection is 1 mm^2 , not less. Wires fastening should exclude mechanical damage, twisting and insulation abrasion of wires.

IT IS NOT ALLOWED TO LEAVE EXPOSED PORTIONS OF WIRE PROTRUDING BEYOND THE REMOVABLE TERMINAL BLOCK.

For reliable contact it is necessary to perform tightening of screws of removable terminal block with the force specified in Table 1.

When reducing the tightening torque, the junction point is heated, the terminal block may be melted and wire can burn. If you increase the tightening torque, it is possible to have thread failure of the terminal block screws or the compression of the connected wire.

To increase the running ability of MCK-108, it is recommended to install protection devices (fuse links or their equivalents) into the following circuits (enumerated in the order of necessity, hyphen is followed by the recommended protection device rating):

- 1) power supply circuits of MCK-108 L, N - 0.5 A;**
- 2) relay output contacts (protection device rating is chosen according to the connected circuits, but shall not exceed 10 A).**

3.1.3 When using the conduction-measuring sensor of liquid level connect the device according to power according to Figure 2. When using the **DR** sensor turn the switch **Off - DR** to "**DR**" (Dry Run) position. When using the emergency level sensor turn the switch **Off - EL** (Off - Emergency Level) to "**EL**" position.

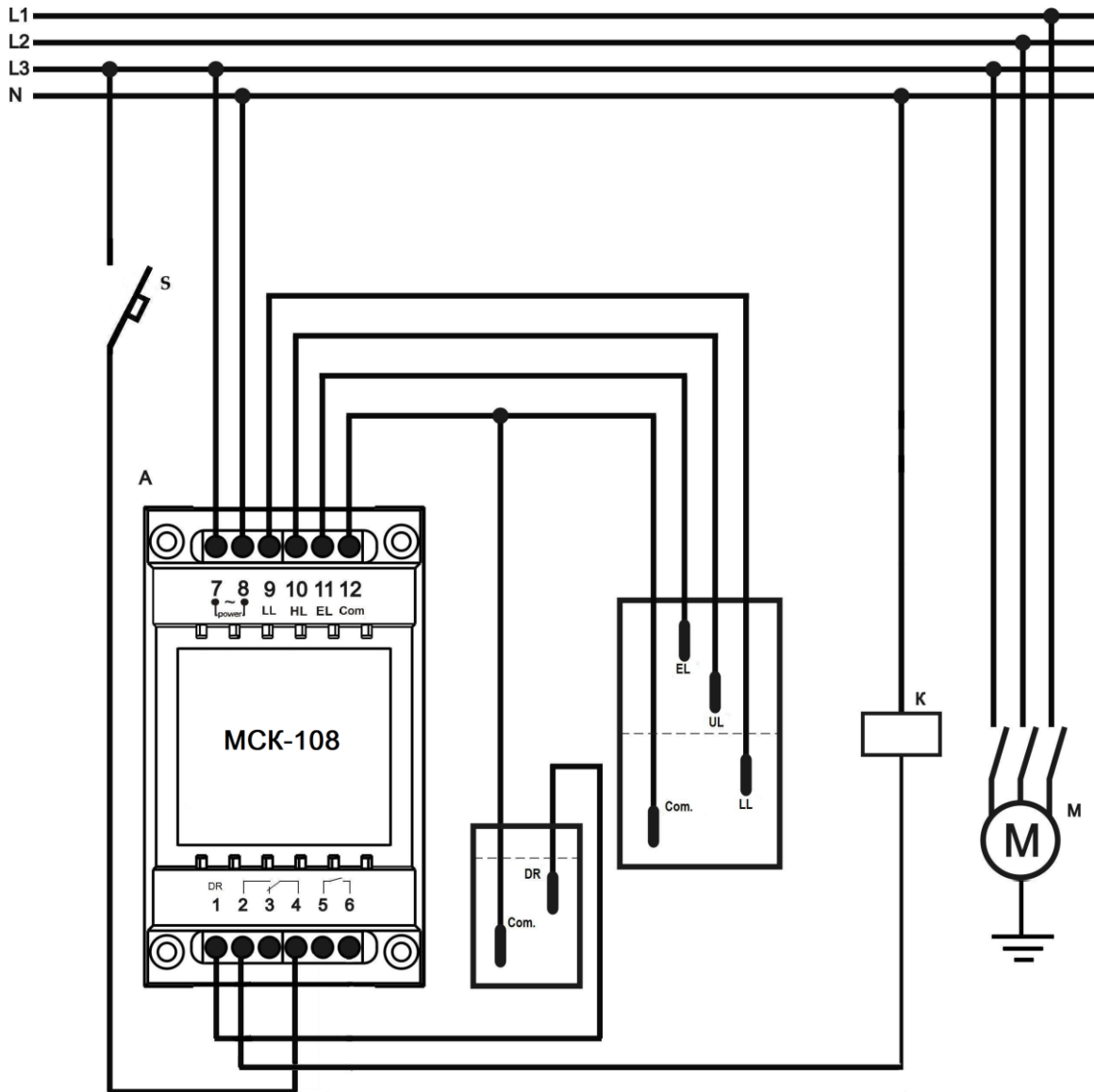

- A – controller of MCK-108
- K – contactor starter
- M – electric motor of the pump
- EL – emergency level sensor
- UL – upper level sensor

- LL – lower level sensor
- DR – dry run sensor
- Com. – common electrode
- S – automatic protector

Figure 2 - Connection Diagram for MCK-108 when working with one pump

3.1.4 When working with one pump, connect the magnetic starter (hereinafter referred to as MS) of the electric motor according to Figure 2 and turn the switch **1 – 2** to "1" position. When working with two pumps, connect MS of the electric motor according to Figure 7 and turn the switch **1 – 2** to "2" position.

3.1.5 When working in the drainage mode, turn the switch **Drn - FI** (Drainage – Filling) to "Drn" position.

3.1.6 When working in the filling mode with level sensors, turn the switch **CPG – S.L.** (CPG – Level Sensor) to "S.L." (Level Sensor) position and turn the switch **Drn - FI** (Drainage – Filling) to "FI" (Filling) position.

3.1.7 To connect the pressure sensor to MCK-108, one must connect the following items by using Figure 1 and Figure 3:

- contacts "1a" and "1b" on CPG with contact "12" on MCK-108;
- contact "2" on CPG with contact "10" on MCK-108;
- contact "3" on CPG with contact "9" on MCK-108;

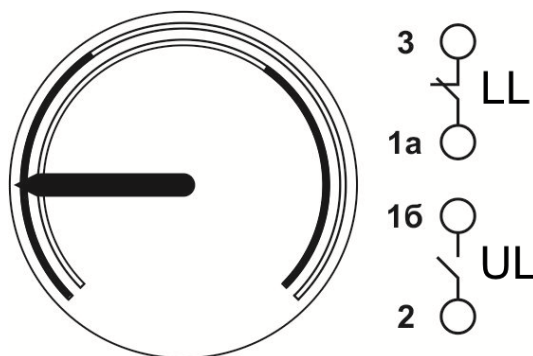

Figure 3 – Connection to Pressure Sensor

3.1.8 When working in the filling mode with the pressure sensor, turn the switch **CPG – S.L.** (CPG – Level Sensor) to "CPG" position and turn the switch **Drn - Fi** (Drainage – Filling) to "Fi" position.

3.1.9 By using the handle **Ths**, adjust the necessary response delay time, which shall exclude false level sensor tripping due to a possible hydraulic shock.

ATTENTION! Don't make excessive efforts when performing adjusting operations.

3.1.10 Turn the handle **Sens** to the position, corresponding to the measured liquid resistance.

3.1.11 By using the handle **Tar**, adjust the necessary AR time, after deactivation of the pump motor due to a dry run failure. Setting the AR time depends on either the time of filling the well or the liquid flow from the tank.

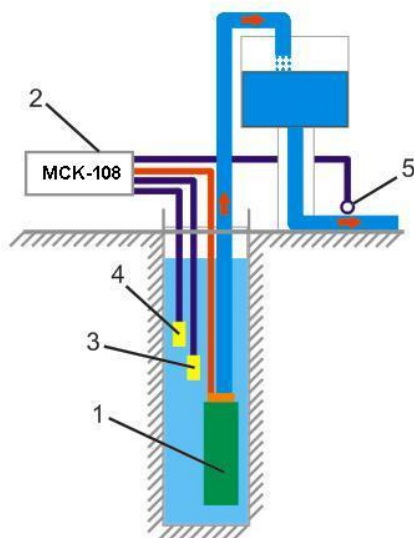

- 1 – submersible pump
- 2 – MCK-108
- 3 – common electrode

- 4 – dry run sensor electrode
- 5 – pressure sensor (CPG or equivalent)

Figure 4– Application of MCK-108 in the filling mode with pressure sensor

3.2 MCK-108 usage

3.2.1 MCK-108 operation with one pump

3.2.1.1 MCK-108 provides operation in the following automated modes:

- **filling** with pressure sensors (Figure 4);
- **filling** with level sensors (Figure 5);
- **drainage** with level sensors (Figure 6).

When operating with one pump:

- the pump relay uses for pump control;
- the functional relay uses for alarm activation.

The alarm is activated (contacts "5 – 6" are closed) in the following cases:

- liquid level is higher than **EL**;
- liquid level is lower than **DR**;
- failure of **UL**, **LL** or **DR** sensors.

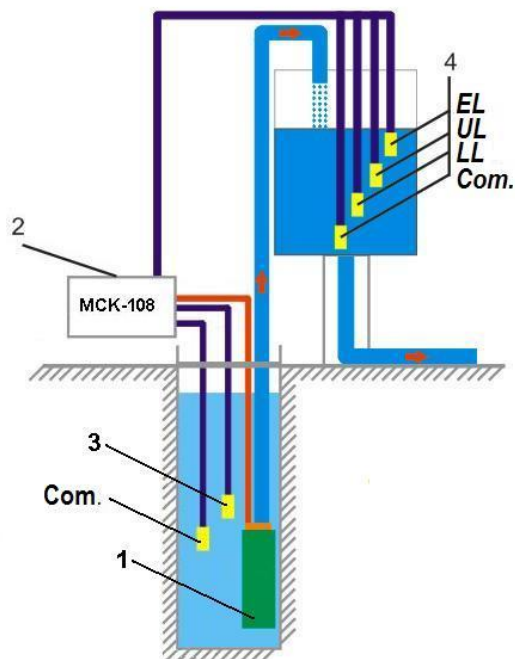

- 1- submersible pump
- 2- MCK-108
- 3 – dry run sensor electrode
- 4 – electrodes:
 - EL – emergency level;
 - UL – upper level;
 - LL – lower level;
 - Com. – common.

Figure 5 – Application of MCK-108 in the filling mode with level sensors

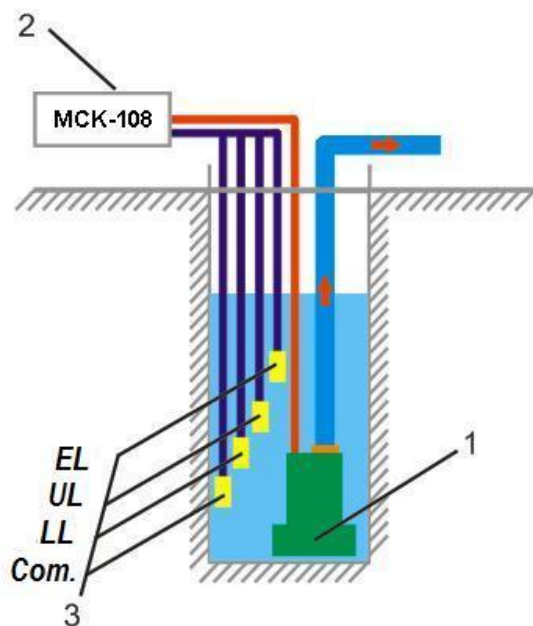

- 1 - submersible pump
- 2 - MCK-108
- 3 – electrodes:
 - EL – emergency level;
 - UL – upper level;
 - LL – lower level;
 - Com. – common.

Figure 6 – Application of MCK-108 in the drainage mode with level sensors

3.2.1.2 Operation in the automated **filling mode** with the pressure sensor

In the initial state (if the movable contact is located between the **UL** and **LL** contacts), when starting the power supply, the electric motor will not be activated.

When closing the movable contact with the contact of the **UL** upper setting, the automatic deactivation of the electric motor takes place.

When closing the movable contact with the contact of the **LL** lower setting, the automatic activation of the electric motor takes place and the cycle is repeated.

3.2.1.3 Operation in the automated **filling mode** with the level sensors

In the initial state (in case there is no liquid in the tank), when starting the power supply, the pump electric motor will be activated automatically.

When the liquid level reaches the **UL** sensor, the automatic deactivation of the electric motor takes place.

When the liquid level in the tank is lower than the **LL** sensor, the automatic activation of the pump electric motor takes place to feed the liquid into the tank and the cycle is repeated.

3.2.1.4 Operation in the automated **drainage mode** with the level sensors

In the initial state (in case the liquid level in the tank is lower than the **UL** sensor), when starting the power supply, the pump electric motor will not be activated.

When the liquid level reaches the **UL** sensor, the automatic activation of the pump electric motor takes place.

When the liquid level in the tank is lower than the **LL** sensor, the automatic deactivation of the pump electric motor takes place and the cycle is repeated.

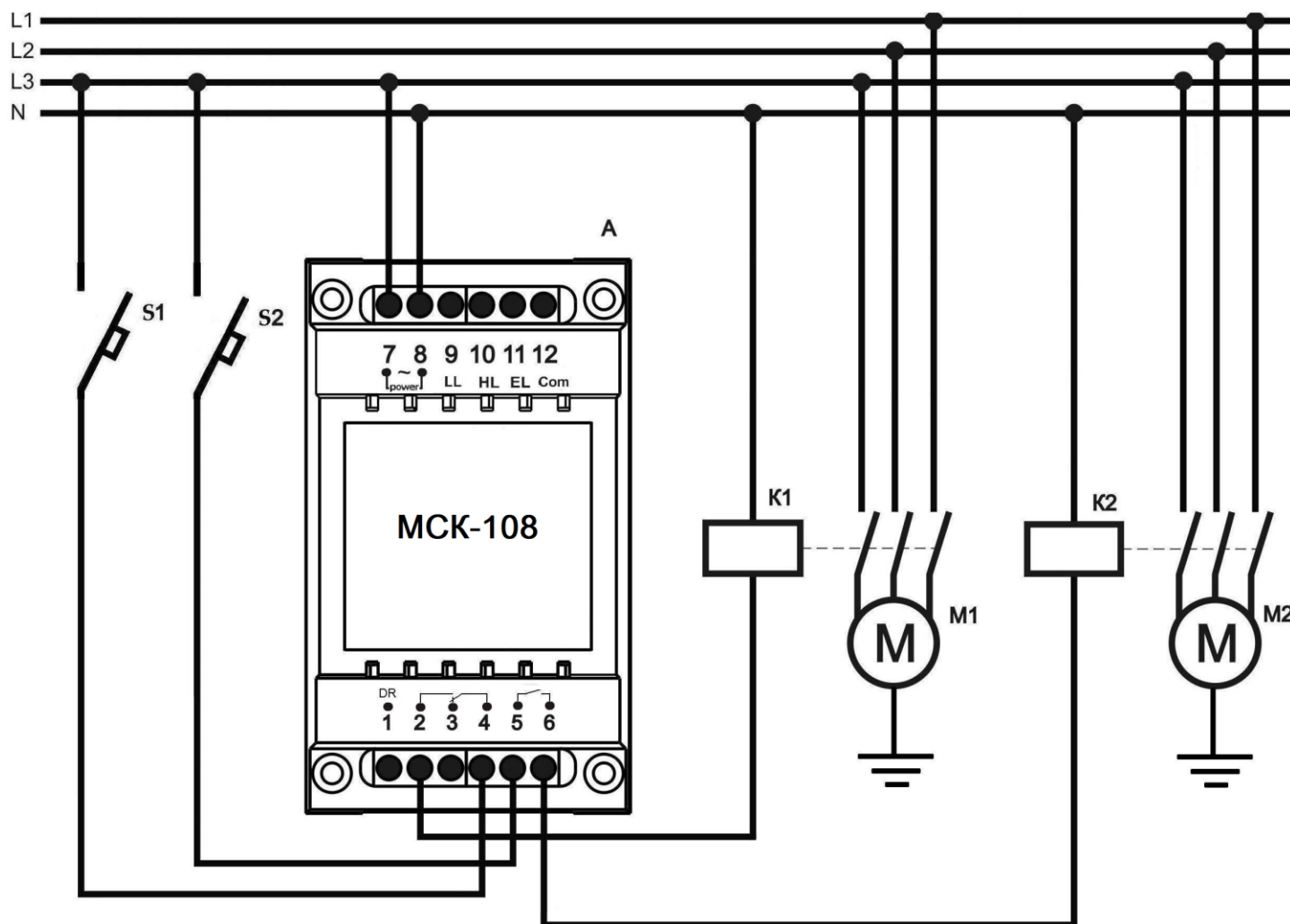

A – MCK-108 controller
 K1,K2 – contactor starter
 M1 – electric motor of the first pump

M2 – electric motor of the second pump
 S1, S2 – automatic protectors

Figure 7 – Connection of two pumps to MCK-108

3.2.2 MCK-108 operation with two pumps

For operating MCK-108 with two pumps, one must connect the contactor starter of the second pump according to Figure 7.

In the automated operation modes of MCK-108 with two pumps, the operation logic of the device is preserved, but the functional relay is used to control the electric motor of the second pump and, subsequently, does not respond to

emergency conditions.

Activation of the electric motors of the pumps (activation of the functional relay and the pump relay) takes place in turn after each deactivated of one of them.

In the automated **drainage mode**, if the emergency level has been reached, the electric motors of the pumps are activated simultaneously.

3.2.3 Emergency conditions

3.2.3.1 Protection of the pump electric motor from the inadmissibly low liquid level in the well

Protection works if the **DR** sensor is activated.

If the liquid level in the well falls lower than the **DR** sensor:

- the pump electric motor is deactivated;
- the LED **DR** starts to glow red;
- the functional relay activates the alarm (at operation with one electric motor).

If the liquid level reaches the **DR** sensor and the AR time elapses, the pump electric motor will be activated.

If the **DR** sensor is off, the LED **DR** goes out.

3.2.3.2 Emergency shutdown of the pump electric motor on tripping of the **EL** emergency level sensor.

If the **EL** sensor is activated, on the liquid level reaching the **EL** sensor:

- in the automated **filling mode** the work of the pump electric motor is forbidden (when working with two pumps the work of both pumps electric motors is forbidden);
- in the automated **drainage mode** the pump electric motor is activated (when working with two pumps the work of both pumps electric motors is allowed) ;
- the LED **EL** starts to glow red;
- when working with one pump electric motor, the functional relay activates the alarm.

If the liquid level falls lower than the **EL** sensor:

- the pump electric motor is activated (when working with two pumps the work of both pumps electric motors is allowed);
 - the LED **EL** goes out;
 - the functional relay deactivates the alarm.
- If the **EL** sensor is off, the LED **EL** goes out.

3.2.3.3 Failures of the (pressure) level sensors are specified in Table 4

Table 4

Name of Failure	Cause	Indication
Failure of the lower level sensor (LL)	If the UL or EL sensor has tripped (except for the operation mode with the pressure sensor), the LL sensor shall indicate the absence of liquid. Or if the UL or EL sensor has tripped (in the operation mode with the pressure sensor), the LL sensor shall indicate a closed condition.	The LED LL blinks red
Failure of the upper level sensor (UL)	If the EL sensor has tripped, the UL sensor shall indicate the absence of liquid.	The LED UL blinks red

At failure of the **UL** sensor, MCK-108 will continue operating, using the emergency level sensor as an **UL** sensor.

3.2.3.4 EEPROM Failure

When EEPROM failure, calibration of resistance of liquid off and MCK-108 is locked, giving the following error message – in turn and with 1 Hz frequency **EL**, **UL**, **LL**, **DR** LEDs starts to glow and upside-down. Then the cycle is repeated.

ATTENTION! In case of EEPROM failure the MCK-108 needs to be laid off and sent for repair.

3 MAINTENANCE

3.1 SAFETY PRECAUTIONS



THE TERMINALS AND THE DEVICE INTERNAL ELEMENTS CONTAINS POTENTIALLY LETHAL VOLTAGE.

DURING MAINTENANCE IT IS NECESSARY TO DISABLE THE DEVICE AND CONNECTED DEVICES FROM THE MAINS.

3.2 Maintenance of the device must be performed by qualified service personnel.

3.3. Recommended frequency of maintenance is **every six months**.

3.4. MAINTENANCE PROCEDURE:

- 1) Check the connection reliability of the wires, if necessary, clamp with the force specified in Table 1;

7 ACCEPTANCE CERTIFICATE

The pumping plant controller MCK-108 is produced and accepted according to the requirements of the effective technical documentation and is acknowledged to be suitable for operation.

Chief of quality department

Date of Issue

STAMP

The Company is grateful to you for the information about the quality of the device and suggestions for its operation.



For all questions, please contact the manufacturer:

"Novatek-Electro" Ltd.
59, Admiral Lazarev str.,
Odessa, 65007, Ukraine
tel: +38 048 738-00-28; +38 0482 37-48-27;
fax: +38 0482 34 36 73
www.novatek-electro.com

Date of Sale _____

VN220721